

Part IB — Methods

Based on lectures by Dr E P Shellard and notes by thirdsgames.co.uk

Michaelmas 2022

Contents

I	Self-Adjoint ODEs	5
1	Fourier Series	5
1.1	Periodic Functions	5
1.2	Definition of Fourier series	6
1.3	Dirichlet conditions	9
1.4	Integration of FS	12
1.5	Differentiation	12
1.6	Parseval's theorem	12
1.7	Half-range series	13
1.8	Complex representation of Fourier series	14
1.9	Self-adjoint matrices	15
1.10	Solving inhomogeneous ODEs with Fourier series	16
2	Sturm-Liouville Theory	19
2.1	Review of second-order linear ODEs	19
2.2	Sturm-Liouville form	20
2.3	Converting to Sturm-Liouville form	20
2.4	Self-adjoint operators	21
2.5	Self-adjoint compatible boundary conditions	22
2.6	Properties of self-adjoint operators	22
2.7	Real eigenvalues	22
2.8	Orthogonality of eigenfunctions	23
2.9	Eigenfunction expansions	24
2.10	Completeness and Parseval's identity	25
2.11	Legendre's equation	26
2.12	Properties of Legendre polynomials	28
2.13	Legendre polynomials as eigenfunctions	28
2.14	Solving inhomogeneous differential equations	29

2.15	Integral solutions and Green's function	30
II	PDEs on Bounded Domains	31
3	The Wave Equation	31
3.1	Waves on an elastic string	31
3.2	Separation of variables	32
3.3	Boundary conditions and normal modes	33
3.4	Initial conditions and temporal solutions	34
3.5	Separation of variables methodology	36
3.6	Energy of oscillations	36
3.7	Wave reflection and transmission	37
3.8	Wave equation in 2D plane polar coordinates	39
3.8.1	Temporal Separation	39
3.8.2	Spatial Separation	39
3.8.3	Polar Solution	40
3.9	Radial Equations	40
3.9.1	Bessel's equation	40
3.9.2	Frobenius Solution	40
3.10	Asymptotic behaviour of Bessel functions	42
3.11	Zeroes of Bessel functions $J_m(z)$	42
3.12	Solving the vibrating drum	43
4	Diffusion equation	46
4.1	Diffusion equation derivation with Fourier's law	46
4.2	Diffusion equation derivation with statistical dynamics	47
4.3	Similarity solutions	47
4.4	Heat conduction in a finite bar	49
4.4.1	Transforming boundary conditions	49
4.4.2	Separation of variables	50
4.5	Particular solution to diffusion equation	50
5	The Laplace Equation	52
5.1	Laplace's equation	52
5.2	Laplace's equation in three-dimensional Cartesian coordinates	52
5.3	Laplace's equation in plane polar coordinates	54
5.3.1	Polar equation	55
5.3.2	Radial equation	55
5.4	Laplace's equation in cylindrical polar coordinates	56
5.5	Laplace's equation in spherical polar coordinates	57
5.5.1	Polar (Legendere) equation	58
5.5.2	Radial equation	58
5.6	General axisymmetric solution	58

5.7	Generating function for Legendre polynomials	59
III	Inhomogenous ODEs; Fourier Transforms	62
6	Dirac delta function	62
6.1	Some limiting approximations	62
6.2	Integral and derivative of delta function	64
6.2.1	Integral of $\delta(x)$	64
6.2.2	Derivative of $\delta(x)$	64
6.3	Properties of delta function	65
6.3.1	Sampling Property	65
6.3.2	Even Property	65
6.3.3	Scaling Property	66
6.3.4	Advanced Scaling Property	66
6.3.5	Isolation Property	67
6.4	Fourier series expansion of delta function	67
6.5	Arbitrary eigenfunction expansion of delta function	67
7	Green's Functions	69
7.1	Physical motivation: Static Forces on a String	69
7.1.1	Direct integration	69
7.1.2	Superposition of point masses	69
7.2	Definition of Green's function	71
7.3	Defining properties (summary)	71
7.4	Explicit form for Green's functions	72
7.4.1	1 & 2, Solve hom eqn with hom b.cs	72
7.4.2	3. Why is G continuous at $x = \xi$?	73
7.4.3	4. Why the jump condition for G' at $x = \xi$	73
7.5	Solving boundary value problems	74
7.6	Higher-order ODEs (BVP)	76
7.7	Eigenfunction expansions of Green's functions	76
7.8	Constructing Green's function for an initial value problem	77
8	Fourier Transforms	79
8.1	Definitions	79
8.2	Converting Fourier series into Fourier transforms	81
8.3	Properties of Fourier series	81
8.4	Convolution theorem	84
8.5	Parseval's theorem	85
8.6	Fourier transforms of generalised functions	86
8.7	Trigonometric functions	86
8.8	Heaviside functions	87
8.9	Dirichlet discontinuous formula	87

8.10 Solving ODEs for boundary value problems	88
8.11 Signal processing	88
8.12 General transfer functions for ODEs	89
8.13 Damped oscillator	90
8.14 Discrete sampling and the Nyquist frequency	91
8.15 Nyquist-Shannon sampling theorem	92
8.16 Discrete Fourier transform	93
8.17 Fast Fourier transform (non-examinable)	95
IV PDEs on Unbounded Domains	96
9 Method of characteristics	96
9.1 Well-posed Cauchy problems	96
9.2 Method of characteristics	96
9.3 Characteristics of a first order PDE	97
9.4 Inhomogeneous first order PDEs	100
9.5 Classification of second order PDEs	101
9.6 Characteristic curves of second order PDEs	102
9.7 Characteristic coordinates	102
9.8 General solution to wave equation	103
10 Solving partial differential equations with Green's functions	105
10.1 Diffusion equation and Fourier transform	105
10.2 Gaussian pulse for heat equation	106
10.3 Forced diffusion equation	106
10.4 Duhamel's principle	108
10.5 Forced wave equation	108
10.6 Poisson's equation	109
10.6.1 Fundamental solutions	110
10.7 Green's identities	111
10.8 Dirichlet Green's function	111
10.9 Neumann Green's Function	112
10.10 Method of images for Laplace's equation	112
10.10.1 Laplace's equation on half-space	113
10.11 Method of images for wave equation	113

Part I

Self-Adjoint ODEs

§1 Fourier Series

§1.1 Periodic Functions

Definition 1.1 (Periodic function)

A function $f(x)$ is **periodic** if $f(x + T) = f(x)$ for all x , where T is the *period*.

For example, simple harmonic motion is periodic. In space, we consider the wavelength $\lambda = \frac{2\pi}{k}$, and the (angular) wave number k is defined conversely by $k = \frac{2\pi}{\lambda}$.

Consider the set of functions

$$g_n(x) = \cos \frac{n\pi x}{L}; \quad h_n(x) = \sin \frac{n\pi x}{L}$$

where $n \in \mathbb{N}$. These functions are periodic on the interval $0 \leq x < 2L$ with period $T = 2L$. Recall that

$$\begin{aligned}\cos A \cos B &= \frac{1}{2}(\cos(A - B) + \cos(A + B)); \\ \sin A \sin B &= \frac{1}{2}(\cos(A - B) - \cos(A + B)); \\ \sin A \cos B &= \frac{1}{2}(\sin(A - B) + \sin(A + B))\end{aligned}$$

Definition 1.2 (Inner product)

We define the **inner product** for two periodic functions f, g on the interval $0 \leq x < 2L$.

$$\langle f, g \rangle = \int_0^{2L} f(x)g(x) dx^a$$

^aWe will generalise this definition later when we use other eigen functions.

The functions g_n and h_n are *mutually orthogonal* on the interval $[0, 2L)$ with respect to the inner product above.

$$\langle h_n, h_m \rangle = \int_0^{2L} \sin \frac{n\pi x}{L} \sin \frac{m\pi x}{L} dx$$

$$\begin{aligned}
&= \frac{1}{2} \int_0^{2L} \left(\cos \frac{(n-m)\pi x}{L} - \cos \frac{(n+m)\pi x}{L} \right) dx \\
&= \frac{1}{2} \frac{L}{\pi} \left[\frac{1}{n-m} \sin \frac{(n-m)\pi x}{L} - \frac{1}{n+m} \sin \frac{(n+m)\pi x}{L} \right]_0^{2L} \\
&= 0 \text{ when } n \neq m
\end{aligned}$$

If $n = m$, we have

$$\langle h_n, h_n \rangle = \int_0^{2L} \sin^2 \frac{n\pi x}{L} dx = \frac{1}{2} \int_0^{2L} \left(1 - \cos \frac{2n\pi x}{L} \right) dx = L \quad (n \neq 0)$$

Thus,

$$\langle h_n, h_m \rangle = \begin{cases} L\delta_{nm} & n, m \neq 0 \\ 0 & nm = 0 \end{cases} \quad (1.1)$$

Similarly, we can show

$$\langle g_n, g_m \rangle = \begin{cases} L\delta_{nm} & n, m \neq 0 \\ 0 & \text{exactly one of } m, n \text{ is zero} \\ 2L & n, m = 0 \end{cases} \quad (1.2)$$

and

$$\langle h_n, g_m \rangle = 0 \quad (1.3)$$

Now, we assert that $\{g_n, h_n\}$ form a complete orthogonal set; they span the space of all 'well-behaved' periodic functions of period $2L$. Further, the set $\{g_n, h_n\}$ is linearly independent.

§1.2 Definition of Fourier series

Since g_n, h_n span the space of 'well-behaved' periodic functions of period $2L$, we can express any such function as a sum of such eigenfunctions.

Definition 1.3 (Fourier series)

The **Fourier series** (FS) of f is

$$f(x) = \frac{1}{2}a_0 + \sum_{n=1}^{\infty} a_n \cos \frac{n\pi x}{L} + \sum_{n=1}^{\infty} b_n \sin \frac{n\pi x}{L} \quad (1.4)$$

where a_n, b_n are constants such that the right hand side is convergent for all x where

f is continuous.^a

^aNote does not require differentiability unlike a Taylor series.

At a discontinuity x , the Fourier series approaches the midpoint of the supremum and infimum of the function in a close neighbourhood of x . That is, we replace the left hand side with

$$\frac{1}{2}f(x_+) + \frac{1}{2}f(x_-)$$

Let $m > 0$, and consider taking the inner product $\langle h_m, f \rangle$ and substituting the Fourier series of f .

$$\begin{aligned}\langle h_m, f \rangle &= \int_0^{2L} \sin \frac{m\pi x}{L} f(x) dx \\ &= \int_0^{2L} \sin \frac{m\pi x}{L} \left(\frac{1}{2}a_0 + \sum_{n=1}^{\infty} a_n \cos \frac{n\pi x}{L} + \sum_{n=1}^{\infty} b_n \sin \frac{n\pi x}{L} \right) dx \text{ by substituting eq. (1.4)} \\ &= \langle h_m, b_m h_m \rangle \text{ by orthogonality relations eqs. (1.1) to (1.3)} \\ &= Lb_m\end{aligned}$$

Thus,

$$\begin{aligned}b_m &= \frac{1}{L} \langle h_m, f \rangle = \frac{1}{L} \int_0^{2L} \sin \frac{m\pi x}{L} f(x) dx \\ a_m &= \frac{1}{L} \langle g_m, f \rangle = \frac{1}{L} \int_0^{2L} \cos \frac{m\pi x}{L} f(x) dx\end{aligned}\tag{1.5}$$

Note. • Note this includes the a_0 case so $\frac{1}{2}a_0$ is the average of the function.

- Note further that we may integrate over any range as long as the total length is one period, $2L$. Notably, we may integrate over the interval $[-L, L]$.
- Think of FS as a decomposition into harmonics. Simplest FS are sine and cosine function, e.g. pure mode $\sin \frac{3\pi x}{L}$, has $b_3 = 1, b_n = 0 \forall n \neq 3$.

Example 1.1 (Sawtooth wave)

Consider the *sawtooth wave*; defined by $f(x) = x$ for $x \in [-L, L)$ and periodic elsewhere.

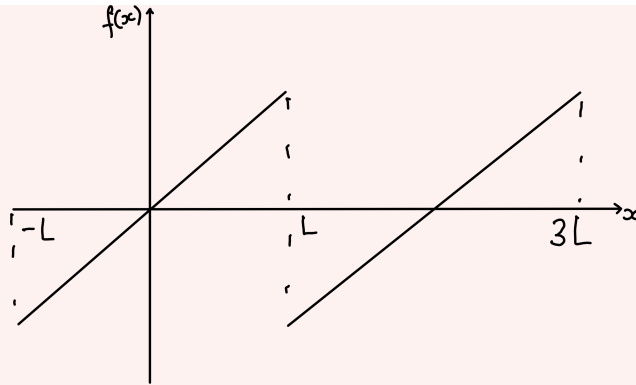

Here, $a_n = \frac{1}{L} \int_{-L}^L x \cos \frac{n\pi x}{L} dx = 0$ as x odd and \cos is even.

$$\begin{aligned}
 b_n &= \frac{1}{L} \int_{-L}^L x \sin \frac{n\pi x}{L} dx \\
 &= \frac{2}{L} \int_0^L x \sin \frac{n\pi x}{L} dx \text{ as the function we are integrating is even} \\
 &= \frac{-2}{n\pi} \left[x \cos \frac{n\pi x}{L} \right]_0^L + \frac{2}{n\pi} \int_0^L \cos \frac{n\pi x}{L} dx \\
 &= \frac{-2L}{n\pi} \cos n\pi + \frac{2L}{(n\pi)^2} \sin n\pi \\
 &= \frac{2L}{n\pi} (-1)^{n+1}
 \end{aligned}$$

So the sawtooth FS is

$$\begin{aligned}
 f(x) &= \frac{2L}{\pi} \sum_{n=1}^{\infty} \frac{(-1)^{n+1}}{n} \sin \frac{n\pi x}{L} \\
 &= \frac{2L}{\pi} \left(\sin \frac{\pi x}{L} - \frac{1}{2} \sin \frac{2\pi x}{L} + \frac{1}{3} \sin \frac{3\pi x}{L} + \dots \right)
 \end{aligned} \tag{1.6}$$

which is slowly convergent.

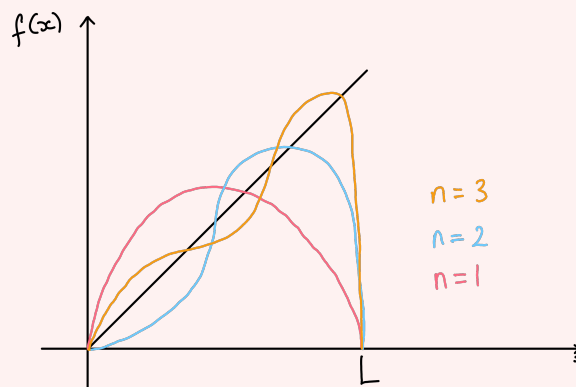

Note. As $n \rightarrow \infty$

1. FS approx improves (convergent when cts)
2. FS $\rightarrow 0$ at $x = L$ i.e. midpoint of discontinuity
3. FS has a persistent overshoot at $x = L$ (approx 9% known as Gibbs phenomenon, see Sheet 1, Q5).

§1.3 Dirichlet conditions

The Dirichlet conditions are sufficiency conditions for a “well-behaved” function, that will imply the existence of a unique Fourier series.

Theorem 1.1

If $f(x)$ is a bounded periodic function of period $2L$ with a finite number of minima, maxima and discontinuities in $[0, 2L)$, then the Fourier series converges to f at all points at which f is continuous, and at discontinuities the series converges to the midpoint.

Note.

1. These are some relatively weak conditions for convergence, compared to Taylor series. However, this definition still eliminates pathological functions such as $\frac{1}{x}$, $\sin \frac{1}{x}$, $\mathbb{1}(\mathbb{Q})$ and so on.
2. **The converse is not true**; for example, $\sin \frac{1}{x}$ does in fact have a Fourier series.
3. The proof is difficult and will not be given.

The rate of convergence of the Fourier series depends on the smoothness of the function.

Theorem 1.2

If $f(x)$ has continuous derivatives^a up to a p th derivative which is discontinuous, then the Fourier series converges with order $O(n^{-(p+1)})$ as $n \rightarrow \infty$.

^aNote it needs to be continuous on \mathbb{R} not on $[0, 2L)$, i.e. it needs to be continuous on $[0, 2L)$ and $f^{(n)}(0) = f^{(n)}(2L)$ as it's periodic.

Example 1.2 ($p = 0$)

Consider the square wave (Sheet 1, Q5)

$$f(x) = \begin{cases} 1 & 0 \leq x < 1 \\ -1 & -1 \leq x < 0 \end{cases}$$

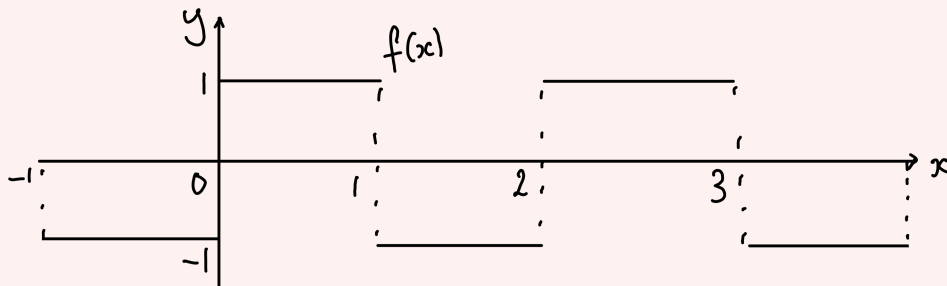

Then the Fourier series is

$$f(x) = 4 \sum_{m=1}^{\infty} \frac{\sin(2m-1)\pi x}{(2m-1)\pi} \quad (1.7)$$

Example 1.3 ($p = 1$)

Consider the general 'see-saw' wave, defined by

$$f(x) = \begin{cases} x(1-\xi) & 0 \leq x < \xi \\ \xi(1-x) & \xi \leq x < 1 \end{cases}$$

and defined as an odd function for $-1 \leq x < 0$. The Fourier series is^a

$$f(x) = 2 \sum_{n=1}^{\infty} \frac{\sin n\pi\xi \sin n\pi x}{(n\pi)^2} \quad (1.8)$$

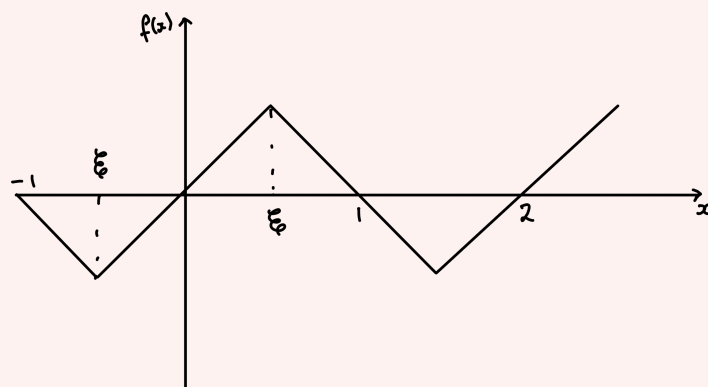

For instance, if $\xi = \frac{1}{2}$, we can show that

$$f(x) = 2 \sum_{m=1}^{\infty} (-1)^{m+1} \frac{\sin(2m-1)\pi x}{((2m-1)\pi)^2}$$

^aThis is an important exercise you should do at home.

Example 1.4 ($p = 2$)

Let

$$f(x) = \frac{1}{2}x(1-x)$$

for $0 \leq x < 1$, and defined as an odd function for $-1 \leq x < 0$. We can show that

$$f(x) = 4 \sum_{n=1}^{\infty} \frac{\sin(2n-1)\pi x}{((2n-1)\pi)^3} \quad (1.9)$$

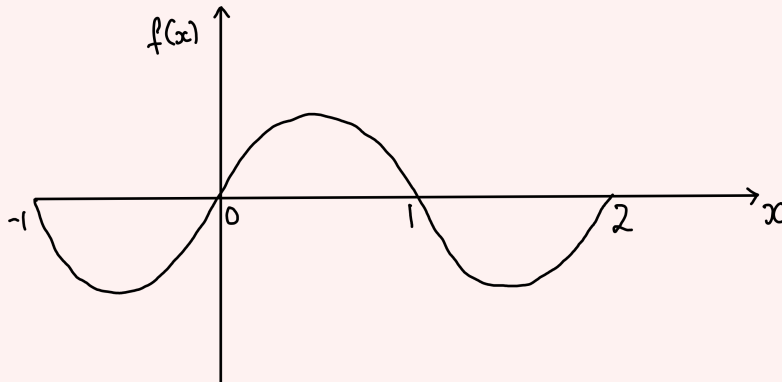

Example 1.5 ($p = 3$)

Consider^a

$$f(x) = (1-x^2)^2$$

with Fourier series

$$a_n = O\left(\frac{1}{n^4}\right)$$

^aSheet 1, Q1

§1.4 Integration of FS

It is always valid to take the integral of a Fourier series term by term. Defining $F(x) = \int_{-L}^x f(x) dx$, we can show that F satisfies the Dirichlet conditions if f does. For instance, a jump discontinuity becomes continuous in the integral.

§1.5 Differentiation

Differentiating term by term is not always valid. For example, consider the square wave above:

$$f(x) \stackrel{?}{=} 4 \sum_{m=1}^{\infty} \cos(2m-1)\pi x$$

which is an unbounded series (consider $x = 0$).

Theorem 1.3

If $f(x)$ is continuous and satisfies the Dirichlet conditions, and $f'(x)$ also satisfies the Dirichlet conditions, then $f'(x)$ can be found term by term by differentiating the Fourier series of $f(x)$.

Example 1.6

We can differentiate the see-saw function, eq. (1.8), with $\xi = \frac{1}{2}$, even though the derivative is not continuous. The result is an offset square wave, or by mapping $x \mapsto x + \frac{1}{2}$ we recover the original square wave, eq. (1.7).

§1.6 Parseval's theorem

Parseval's theorem relates the integral of the square of a function with the sum of the squares of the function's Fourier series coefficients.

Theorem 1.4 (Parseval's theorem)

Suppose f has Fourier coefficients a_i, b_i . Then

$$\int_0^{2L} [f(x)]^2 dx = \int_0^{2L} \left[\frac{1}{2} a_0 + \sum_{n=1}^{\infty} a_n \cos \frac{n\pi x}{L} + \sum_{n=1}^{\infty} b_n \sin \frac{n\pi x}{L} \right]^2 dx$$

We can remove cross terms, since the basis functions are orthogonal. eqs. (1.1) to (1.3)

$$\begin{aligned}
 &= \int_0^{2L} \left[\frac{1}{4}a_0^2 + \sum_{n=1}^{\infty} a_n^2 \cos^2 \frac{n\pi x}{L} + \sum_{n=1}^{\infty} b_n^2 \sin^2 \frac{n\pi x}{L} \right] dx \\
 &= L \left[\frac{1}{2}a_0^2 + \sum_{n=1}^{\infty} (a_n^2 + b_n^2) \right] \tag{1.10}
 \end{aligned}$$

This is also called the *completeness relation*: the left hand side is greater than or equal to the right hand side if any of the basis functions are missing.

Example 1.7

Let us apply Parseval's theorem to the sawtooth wave with FS eq. (1.6).

$$\int_{-L}^L [f(x)]^2 dx = \int_{-L}^L x^2 dx = \frac{2}{3}L^3$$

The right hand side gives

$$L \sum_{n=1}^{\infty} \frac{4L^2}{n^2\pi^2} = \frac{4L^3}{\pi^2} \sum_{n=1}^{\infty} \frac{1}{n^2}$$

Parseval's theorem then implies^a

$$\sum_{n=1}^{\infty} \frac{1}{n^2} = \frac{\pi^2}{6}$$

^aSheet 1, Q3

Note. Parseval's theorem for functions $\langle f, f \rangle = \|f\|^2$ is equivalent to Pythagoras for vectors $\langle v, v \rangle = \|v\|^2$.

§1.7 Half-range series

Consider $f(x)$ defined only on $0 \leq x < L$. We can extend the range of f to be the full range $-L \leq x < L$ in two simple ways:

1. require f to be odd, so $f(-x) = -f(x)$. Hence, $a_n = 0$ (as cos is even) and

$$b_n = \frac{2}{L} \int_0^L f(x) \sin \frac{n\pi x}{L} dx \tag{1.11}$$

So

$$f(x) = \sum_{n=1}^{\infty} b_n \sin \frac{n\pi x}{L}$$

which is called a Fourier sine series.

2. require f to be even, so $f(-x) = f(x)$. In this case, $b_n = 0$ and

$$a_n = \frac{2}{L} \int_0^L f(x) \cos \frac{n\pi x}{L} dx \quad (1.12)$$

and so

$$f(x) = \frac{1}{2}a_0 + \sum_{n=1}^{\infty} a_n \cos \frac{n\pi x}{L}$$

which is a Fourier cosine series.

§1.8 Complex representation of Fourier series

Recall that

$$\begin{aligned} \cos \frac{n\pi x}{L} &= \frac{1}{2} \left(e^{in\pi x/L} + e^{-in\pi x/L} \right); \\ \sin \frac{n\pi x}{L} &= \frac{1}{2i} \left(e^{in\pi x/L} - e^{-in\pi x/L} \right) \end{aligned}$$

Therefore, a Fourier series can be written as

$$\begin{aligned} f(x) &= \frac{1}{2}a_0 + \frac{1}{2} \sum_{n=1}^{\infty} \left[(a_n - ib_n)e^{in\pi x/L} + (a_n + ib_n)e^{-in\pi x/L} \right] \\ &= \sum_{m=-\infty}^{\infty} c_m e^{im\pi x/L} \end{aligned} \quad (1.13)$$

where for $m > 0$ we have $m = n$, $c_m = \frac{1}{2}(a_n - ib_n)$, and for $m < 0$ we have $n = -m$, $c_m = \frac{1}{2}(a_{-m} + ib_{-m})$, and where $m = 0$ we have $c_0 = \frac{1}{2}a_0$. In particular,

$$c_m = \frac{1}{2L} \int_{-L}^L f(x) e^{-im\pi x/L} dx \quad (1.14)$$

where the negative sign comes from the complex conjugate. This is because, for complex-valued f, g , we have

Definition 1.4 (Complex inner product)

$$\langle f, g \rangle = \int_{-L}^L f^{*a} g \, dx$$

^a f^* is the complex conjugate of f .

The orthogonality conditions are

$$\int_{-L}^L e^{-im\pi x/L} e^{in\pi x/L} \, dx = 2L\delta_{mn} \quad (1.15)$$

Parseval's theorem now states

$$\int_{-L}^L f^*(x)f(x) \, dx = \int_{-L}^L |f(x)|^2 \, dx = 2L \sum_{m=-\infty}^{\infty} |c_m|^2$$

§1.9 Self-adjoint matrices

Much of this section is a recap of IA Vectors and Matrices. Suppose that $u, v \in \mathbb{C}^N$ with inner product

$$\langle u, v \rangle = u^\dagger v \quad (1.16)$$

Definition 1.5 (Hermitian matrix)

The $N \times N$ matrix A is *self-adjoint*, or *Hermitian*, if

$$\forall u, v \in \mathbb{C}^N, \langle Au, v \rangle = \langle u, Av \rangle \iff A^\dagger = A$$

The eigenvalues λ_n and eigenvectors v_n satisfy

$$Av_n = \lambda_n v_n \quad (1.17)$$

They have the following properties:

1. $\lambda_n^* = \lambda_n$;
2. $\lambda_n \neq \lambda_m \implies \langle v_n, v_m \rangle = 0$;
3. we can create an orthonormal basis from the eigenvectors.

Given $b \in \mathbb{C}^n$, we can solve for x in the general matrix equation

$$Ax = b \quad (1.18)$$

Express b in terms of the eigenvector basis:

$$b = \sum_{n=1}^N b_n v_n$$

We seek a solution of the form

$$x = \sum_{n=1}^N c_n v_n$$

At this point, the b_n are known and the c_n are our target. Substituting into the matrix equation eq. (1.18), orthogonality of basis vectors gives

$$\begin{aligned} A \sum_{n=1}^N c_n v_n &= \sum_{n=1}^N b_n v_n \\ \sum_{n=1}^N c_n \lambda_n v_n &= \sum_{n=1}^N b_n v_n \end{aligned}$$

As the eigenvector basis is orthogonal we can equate coefficients

$$\begin{aligned} c_n \lambda_n &= b_n \\ c_n &= \frac{b_n}{\lambda_n} \end{aligned}$$

Therefore,

$$x = \sum_{n=1}^N \frac{b_n}{\lambda_n} v_n \quad (1.19)$$

provided $\lambda_n \neq 0$, or equivalently, the matrix is invertible.

§1.10 Solving inhomogeneous ODEs with Fourier series

We wish to find $y(x)$ given a driving/ source term $f(x)$ for the general differential equation

$$\mathcal{L}y \equiv -\frac{d^2 y}{dx^2} = f(x) \quad (1.20)$$

with boundary conditions $y(0) = y(L) = 0$. The related eigenvalue problem is

$$\mathcal{L}y_n = \lambda_n y_n, \quad y_n(0) = y_n(L) = 0$$

which has solutions

$$y_n(x) = \sin \frac{n\pi x}{L}, \lambda_n = \left(\frac{n\pi}{L}\right)^2 \quad (1.21)$$

We can show that this is a self-adjoint linear operator¹ with orthogonal eigenfunctions. We seek solutions of the form of a half-range sine series. Consider

$$y(x) = \sum_{n=1}^{\infty} c_n \sin \frac{n\pi x}{L}$$

The right hand side is

$$f(x) = \sum_{n=1}^{\infty} b_n \sin \frac{n\pi x}{L}$$

We can find b_n by

$$b_n = \frac{2}{L} \int_0^L f(x) \sin \frac{n\pi x}{L} dx$$

Substituting into eq. (1.20), we have

$$\begin{aligned} \mathcal{L}y &= -\frac{d^2}{dx^2} \left(\sum_n c_n \sin \frac{n\pi x}{L} \right) = \sum_n c_n \left(\frac{n\pi}{L}\right)^2 \sin \frac{n\pi x}{L} \\ \text{So } \sum_n c_n \left(\frac{n\pi}{L}\right)^2 \sin \frac{n\pi x}{L} &= \sum_n b_n \sin \frac{n\pi x}{L} \end{aligned}$$

By orthogonality eq. (1.1),

$$c_n \left(\frac{n\pi}{L}\right)^2 = b_n \implies c_n = \left(\frac{L}{n\pi}\right)^2 b_n$$

Therefore the solution is

$$y(x) = \sum_n \left(\frac{L}{n\pi}\right)^2 b_n \sin \frac{n\pi x}{L} = \sum_n \frac{b_n}{\lambda_n} y_n \quad (1.22)$$

which is equivalent to the solution we found for self-adjoint matrices for which the eigenvalues and eigenvectors are known.

Example 1.8 (Odd square wave)

Consider an odd square wave with $L = 1$, so $f(x) = 1$ from $0 \leq x < 1$.

$$f(x) = 4 \sum_m \frac{\sin(2m-1)\pi x}{(2m-1)\pi} \text{ by eq. (1.7)}$$

¹<https://math.stackexchange.com/questions/4356100/why-is-the-second-derivative-operator-self-adjoint>

Then the solution to $\mathcal{L}y = f$ eq. (1.22) should be (with odd $n = 2m - 1$)

$$y(x) = \sum_n \frac{b_n}{\lambda_n} y_n = 4 \sum_n \frac{\sin(2m-1)\pi x}{((2m-1)\pi)^3}$$

This is exactly the Fourier series eq. (1.9) for

$$y(x) = \frac{1}{2}x(1-x) \tag{1.23}$$

so this y is the solution to the differential equation. We can in fact integrate $\mathcal{L}y = 1$ directly with the boundary conditions to verify the solution. We can also differentiate the Fourier series for y twice to find the square wave.

§2 Sturm-Liouville Theory

§2.1 Review of second-order linear ODEs

This section is a review of IA Differential Equations.

We wish to solve a general inhomogeneous ODE, written

$$\mathcal{L}y \equiv \alpha(x)y'' + \beta(x)y' + \gamma(x)y = f(x) \quad (2.1)$$

The homogeneous version has $f(x) = 0$, so

$$\mathcal{L}y = 0, \quad (2.2)$$

which has two independent solutions y_1, y_2 . The general solution, also the complementary function for the inhomogeneous ODE, is

$$y_c(x) = Ay_1(x) + By_2(x). \quad (2.3)$$

The inhomogeneous equation

$$\mathcal{L}y = f(x) \quad (2.4)$$

has a solution called the particular integral, denoted $y_p(x)$. The general solution to this equation is then

$$y(x) = y_p + y_c. \quad (2.5)$$

We need two boundary or initial conditions to find the particular solution to the differential equation. Suppose $x \in [a, b]$. We can create boundary conditions by defining $y(a), y(b)$, often called the Dirichlet conditions. Alternatively, we can consider $y(a), y'(a)$, called the Neumann conditions. We could also use some kind of mixed condition, for instance $y + ky'$.

Homogeneous boundary conditions are such that $y(a) = y(b) = 0$. In this part of the course, homogeneous boundary conditions are often assumed. Note that we can add a complementary function y_c to the solution, for instance $\bar{y} = y + Ay_1 + By_2$ such that $\bar{y}(a) = \bar{y}(b) = 0$. This would allow us to construct homogeneous boundary conditions even when they are not present *a priori* in the problem. We could also specify initial data, such as solving for $x \geq a$, given y, y' at $x = a$.

To solve the inhomogeneous equation eq. (2.1), we want to use eigenfunction expansions (like FS eq. (1.22)). In order to do this, we must first solve the related eigenvalue problem. In this case, that is

$$\alpha(x)y'' + \beta(x)y' + \gamma(x)y = -\lambda\rho(x)y. \quad (2.6)$$

We must solve this equation with the same boundary conditions as the original problem. This form of equation often arises as a result of applying a separation of variables, particularly for PDEs in several dimensions.

§2.2 Sturm-Liouville form

Definition 2.1 (Inner product)

For two complex-valued functions f, g on $[a, b]$, we define the inner product as

$$\langle f, g \rangle = \int_a^b f^*(x)g(x) dx$$

The eigenvalue problem eq. (2.6) above greatly simplifies if \mathcal{L} is self-adjoint, that is, if it can be expressed in Sturm-Liouville form:

$$\mathcal{L}y \equiv -(py')' + qy = \lambda wy. \quad (2.7)$$

λ is an eigenvalue, and $w(x)$ is the *weight function*, which must be non-negative $w(x) \geq 0 \forall x$.

§2.3 Converting to Sturm-Liouville form

Multiply eq. (2.6) by an integrating factor $F(x)$ to give

$$\begin{aligned} F\alpha y'' + F\beta y' + F\gamma y &= -\lambda F\rho y \\ \frac{d}{dx}(F\alpha y') - F'\alpha y' - F\alpha'y' + F\beta y' + F\gamma y &= -\lambda F\rho y \end{aligned}$$

To eliminate the y' term, we require $F'\alpha = F(\beta - \alpha')$. Thus,

$$\begin{aligned} \frac{F'}{F} &= \frac{\beta - \alpha'}{\alpha} \\ \implies F &= \exp \int^x \frac{\beta - \alpha'}{\alpha} dx \end{aligned} \quad (2.8)$$

and further,

$$(F\alpha y')' + F\gamma y = -\lambda F\rho y$$

hence

$$\begin{aligned} p &= F\alpha \\ q &= -F\gamma \\ w &= F\rho \end{aligned}$$

in eq. (2.7) and $F(x) > 0$ hence $w > 0$.

Example 2.1

Consider the Hermite equation for simple harmonic oscillator,

$$y'' - 2xy' + 2ny = 0$$

In this case for eq. (2.6) $\alpha = 1$, $\beta = -2x$, $\gamma = 0$, $\lambda p = 2n$. So by eq. (2.8)

$$F = \exp \int^x \frac{-2x}{1} dx = e^{-x^2}$$

Then the equation, in Sturm-Liouville form, is

$$\mathcal{L}y \equiv -(e^{-x^2} y')' = 2ne^{-x^2} y \quad (2.9)$$

§2.4 Self-adjoint operators

Definition 2.2 (Self-adjoint operator)

\mathcal{L} is a self-adjoint operator on $[a, b]$ for all pairs of functions y_1, y_2 satisfying appropriate boundary conditions if

$$\langle y_1, \mathcal{L}y_2 \rangle = \langle \mathcal{L}y_1, y_2 \rangle$$

Written explicitly,

$$\int_a^b y_1^*(x) \mathcal{L}y_2(x) dx = \int_a^b (\mathcal{L}y_1(x))^* y_2(x) dx \quad (2.10)$$

Boundary conditions: Substituting Sturm-Liouville form eq. (2.7) into the above,

$$\begin{aligned} \langle y_1, \mathcal{L}y_2 \rangle - \langle \mathcal{L}y_1, y_2 \rangle &= \int_a^b [-y_1(py_2')' + y_1qy_2 + y_2(py_1')' - y_2qy_1] dx \\ &= \int_a^b [-y_1(py_2')' + y_2(py_1')'] dx \end{aligned}$$

Adding $-y_1'py_2' + y_1'py_2'$,

$$\begin{aligned} &= \int_a^b [-(py_1y_2')' + (py_1'y_2)'] dx \\ &= [-py_1y_2' + py_1'y_2]_a^b \end{aligned} \quad (2.11)$$

which must be zero for an equation in Sturm-Liouville form to be self-adjoint.

§2.5 Self-adjoint compatible boundary conditions

- Suppose $y(a) = y(b) = 0$. Then certainly the Sturm-Liouville form of the differential equation is self-adjoint. We could also choose $y'(a) = y'(b) = 0$ or $y + ky' = 0$. Collectively, the act of using homogeneous boundary conditions is known as the *regular* Sturm-Liouville problem.
- Periodic boundary conditions could also be used, such as $y(a) = y(b)$.
- If a and b are singular points of the equation, i.e. $p(a) = p(b) = 0$, this is self-adjoint compatible.
- We could also have combinations of the above properties, one at a and one at b .

§2.6 Properties of self-adjoint operators

The following properties hold for any self-adjoint differential operator \mathcal{L} .

1. The eigenvalues λ_n are real (also eigenfunctions are real).
2. The eigenfunctions y_n are orthogonal.
3. The y_n are a complete set; they span the space of all functions hence our general solution can be written in terms of these eigenfunctions.

Each property is proven in its own subsection.

§2.7 Real eigenvalues

Proof. Suppose we have some eigenvalue λ_n , so

$$\mathcal{L}y_n = \lambda_n w y_n. \quad (2.12)$$

Taking the complex conjugate, $\mathcal{L}y_n^* = \lambda_n^* w y_n^*$, since \mathcal{L}, w are real. Now, consider

$$\int_a^b (y_n^* \mathcal{L}y_n - y_n \mathcal{L}y_n^*) dx$$

which must be zero if \mathcal{L} is self-adjoint, eq. (2.10). This can be written as

$$(\lambda_n - \lambda_n^*) \int_a^b w y_n^* y_n dx = 0$$

The integral is nonzero, hence $\lambda_n - \lambda_n^* = 0$ which implies λ_n is real. \square

Aside

Note, if the λ_n are non-degenerate (simple), i.e. with a unique eigenfunction y_n , then $y_n^* = y_n$ hence they are real. We can in fact show that (for a second-order equation) it is always possible to take linear combinations of eigenfunctions such that the result is linear, for example in the exponential form of the Fourier series. Hence, we can assume that y_n is real.

We can further prove that the regular Sturm-Liouville problem must have simple (non-degenerate) eigenvalues λ_n , by considering two possible eigenfunctions u, v for the same λ , and use the expression for self-adjointness. We find $u\mathcal{L}v - (\mathcal{L}u)v = [-p(uv' - u'v)]'$ which contains the Wronskian. We can integrate and impose homogeneous boundary conditions to get the required result.

§2.8 Orthogonality of eigenfunctions

Suppose $\mathcal{L}y_n = \lambda_n w y_n$ eq. (2.12), and $\mathcal{L}y_m = \lambda_m w y_m$ where $\lambda_n \neq \lambda_m$. Then, we can integrate to find

$$\int_a^b (y_m \mathcal{L}y_n - y_n \mathcal{L}y_m) dx = (\lambda_n - \lambda_m) \int_a^b w y_n y_m dx = 0 \text{ by self-adjointness eq. (2.10)}$$

Since $\lambda_n \neq \lambda_m$, we have

$$\forall n \neq m, \int_a^b w y_n y_m dx = 0 \quad (2.13)$$

Hence, y_n and y_m are orthogonal *with respect to* the weight function w on $[a, b]$.

Definition 2.3 (Inner product)

We define the inner product with respect to w to be

$$\langle f, g \rangle_w = \int_a^b w(x) f^*(x) g(x) dx \quad (2.14)$$

Note,

$$\langle f, g \rangle_w = \langle wf, g \rangle = \langle f, wg \rangle$$

Hence, the orthogonality relation becomes

$$\forall n \neq m, \langle y_n, y_m \rangle_w = 0. \quad (2.15)$$

§2.9 Eigenfunction expansions

The completeness of the family of eigenfunctions (which is not proven here) implies that we can approximate any ‘well-behaved’ $f(x)$ on $[a, b]$ by the series

$$f(x) = \sum_{n=1}^{\infty} a_n y_n(x) \quad (2.16)$$

This is comparable to Fourier series. To find the coefficients a_n , we will take the inner product with an eigenfunction. By orthogonality,

$$\begin{aligned} \int_a^b w y_m f \, dx &= \sum_{n=1}^{\infty} a_n \int_a^b w y_n y_m \, dx \\ &= a_m \int_a^b w y_m^2 \, dx \text{ by orthogonality eq. (2.13)} \end{aligned}$$

Hence,

$$a_n = \frac{\int_a^b w y_n f \, dx}{\int_a^b w y_n^2 \, dx} \quad (2.17)$$

We can normalise eigenfunctions, for instance

$$Y_n(x) = \frac{y_n(x)}{\left(\int_a^b w y_n^2 \, dx\right)^{\frac{1}{2}}} \quad (2.18)$$

hence

$$\langle Y_n, Y_m \rangle_w = \delta_{nm}$$

giving an orthonormal set of eigenfunctions. In this case,

$$f(x) = \sum_{n=1}^{\infty} A_n Y_n$$

where

$$A_n = \int_a^b w Y_n f \, dx$$

Example 2.2

Recall Fourier series in Sturm-Liouville form eq. (1.21):

$$\mathcal{L}y_n \equiv -\frac{d^2 y}{dx^2} = \lambda_n y_n$$

where in this case we have

$$\lambda_n = \left(\frac{n\pi}{L}\right)^2$$

by orthogonality relations eqs. (1.1) to (1.3)

§2.10 Completeness and Parseval's identity

Consider

$$\int_a^b \left[f(x) - \sum_{n=1}^{\infty} a_n y_n \right]^2 w \, dx$$

By orthogonality eq. (2.13), this is equivalently

$$\int_a^b \left[f^2 - 2f \sum_n a_n y_n + \sum_n a_n^2 y_n^2 \right] w \, dx = \int_a^b w f^2 \, dx - \sum_{n=1}^{\infty} \left(2a_n \int_a^b f y_n w \, dx - a_n^2 \int_a^b w y_n^2 \, dx \right)$$

Note that the second term can be extracted using the definition of a_n ($\int f y_n w \, dx = a_n \int w y_n^2 \, dx$) eq. (2.17), giving

$$\int_a^b w f^2 \, dx - \sum_{n=1}^{\infty} a_n^2 \int_a^b w y_n^2 \, dx$$

If the eigenfunctions are complete, then the result will be zero, showing that the series expansion converges.

$$\begin{aligned} \int_a^b w f^2 \, dx &= \sum_{n=1}^{\infty} a_n^2 \int_a^b w y_n^2 \, dx \\ &= \sum_{n=1}^{\infty} A_n^2 \text{ for unit normalised } Y_n \text{ eq. (2.18)} \end{aligned} \tag{2.19}$$

If some eigenfunctions are missing, this is Bessel's inequality:

$$\int_a^b w f^2 \, dx \geq \sum_{n=1}^{\infty} A_n^2$$

We define the partial sum to be

$$S_N(x) = \sum_{n=1}^N a_n y_n$$

with

$$f(x) = \lim_{N \rightarrow \infty} S_N(x). \tag{2.20}$$

Convergence is defined in terms of the mean-square error. In particular, if we have a complete set of eigenfunctions,

$$\varepsilon_N = \int_a^b w[f(x) - S_N(x)]^2 dx \rightarrow 0$$

This ‘global’ definition of convergence is convergence in the mean, not pointwise convergence as in Fourier series². The error in partial sum S_N is minimised by a_n above for the $N = \infty$ expansion.

$$\begin{aligned} \frac{\partial \varepsilon_N}{\partial a_n} &= -2 \int_a^b y_n w \left[f - \sum_{n=1}^N a_n y_n \right] dx \\ &= -2 \int_a^b (w f y_n - a_n w y_n^2) dx \\ &= 0 \text{ if } a_n \text{ given by eq. (2.17)} \end{aligned}$$

It is minimal because we can show $\frac{\partial^2 \varepsilon}{\partial a_n^2} = 2 \int_a^b w y_n^2 dx \geq 0$. Thus the a_n given in eq. (2.17) is the best possible choice for the coefficient at all N .

§2.11 Legendre’s equation

Consider Legendre’s equation arising from $\nabla^2 u = 0$ in spherical polars with $x = \cos \theta$. Legendre’s equation is

$$(1 - x^2)y'' - 2xy' + \lambda y = 0 \tag{2.21}$$

on $x \in [-1, 1]$, with boundary conditions that y is finite at $x = \pm 1$, at the regular singular points of the ODE. This equation is already in Sturm-Liouville form, eq. (2.7), with

$$p = 1 - x^2, q = 0, w = 1.$$

We seek a power series solution centred on $x = 0$:

$$y = \sum_n c_n x^n.$$

Substituting into eq. (2.21),

$$(1 - x^2) \sum_n n(n-1)c_n x^{n-2} - 2x \sum_n c_n x^{n-1} + \lambda \sum_n c_n x^n = 0$$

Equating powers of x^n ,

$$(n+2)(n+1)c_{n+2} - n(n-1)c_n - 2nc_n + \lambda c_n = 0$$

²convergence in mean is weaker than pointwise convergence

which gives a recursion relation between c_{n+2} and c_n .

$$c_{n+2} = \frac{n(n+1) - \lambda}{(n+1)(n+2)} c_n \quad (2.22)$$

Hence, specifying c_0, c_1 gives two independent solutions. In particular,

$$y_{\text{even}} = c_0 \left[1 + \frac{(-\lambda)}{2!} x^2 + \frac{(6-\lambda)(-\lambda)}{4!} x^4 + \dots \right]$$

$$y_{\text{odd}} = c_1 \left[x + \frac{(2-\lambda)}{3!} x^3 + \dots \right]$$

As $n \rightarrow \infty$, $\frac{c_{n+2}}{c_n} \approx \frac{n^2}{n^2} \rightarrow 1$. So these are geometric series, with radius of convergence $|x| < 1$, hence there is divergence at $x = \pm 1$. So taking a power series does not give a useful solution.

Suppose we chose $\lambda = \ell(\ell + 1)$. Then eventually we have n such that the numerator vanishes. In particular, by taking $\lambda = \ell(\ell + 1)$, either the series for y_{even} or y_{odd} terminates. These functions are called the **Legendre polynomials**, denoted $P_\ell(x)$, are eigenfunctions of eq. (2.21) on $-1 \leq x \leq 1$ with the normalisation convention $P_\ell(1) = 1$ (not unit normalised).

- $\ell = 0, \lambda = 0, P_0(x) = 1$
- $\ell = 1, \lambda = 2, P_1(x) = x$
- $\ell = 2, \lambda = 6, P_2(x) = \frac{3x^2 - 1}{2}$
- $\ell = 3, \lambda = 12, P_3(x) = \frac{5x^3 - 3x}{2}$

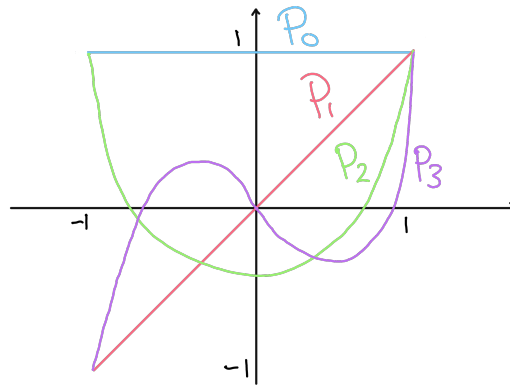

Note. $P_\ell(x)$ has ℓ zeroes. P_ℓ is odd if ℓ is odd, P_ℓ is even for even ℓ .

§2.12 Properties of Legendre polynomials

Since Legendre polynomials come from a self-adjoint operator, they must have certain conditions, such as orthogonality. For $n \neq m$,

$$\int_{-1}^1 P_n P_m dx = 0$$

They are also normalisable,

$$\int_{-1}^1 P_n^2 dx = \frac{2}{2n+1} \quad (2.24)$$

We can prove this with Rodrigues' formula (Sheet 2, Q5):

$$P_n(x) = \frac{1}{2^n n!} \left(\frac{d}{dx} \right)^n (x^2 - 1)^n$$

Alternatively we could use a generating function:

$$\begin{aligned} \sum_{n=0}^{\infty} P_n(x)t^n &= \frac{1}{\sqrt{1-2xt+t^2}} & (2.23a) \\ &= 1 + \frac{1}{2}(2xt - t^2) + \frac{3}{8}(2xt - t^2)^2 + \dots \\ &= 1 + xt + \frac{1}{2}(3x^2 - 1)t^2 + \dots \\ &= P_0 + P_1 t + P_2 t^2 + \dots \end{aligned}$$

Exercise 2.1. Verify P_3 and find P_4 using binomial expansion.

There are some useful recursion relations³.

$$\ell(\ell+1)P_{\ell+1}(x) = (2\ell+1)xP_{\ell}(x) - \ell P_{\ell-1}(x)$$

Also,

$$(2\ell+1)P_{\ell}(x) = \frac{d}{dx}[P_{\ell+1}(x) - P_{\ell-1}(x)]$$

§2.13 Legendre polynomials as eigenfunctions

Any (well-behaved) function $f(x)$ on $[-1, 1]$ can be expressed as

$$f(x) = \sum_{\ell=0}^{\infty} a_{\ell} P_{\ell}(x) \quad (2.25)$$

³Derived in Example Sheet

where

$$a_\ell = \frac{2\ell + 1}{2} \int_{-1}^1 f(x) P_\ell(x) dx \quad (2.26)$$

with no boundary conditions (e.g. periodicity conditions) on f .

Exercise 2.2. Verify $f(x) = \frac{15}{2}x^2 - \frac{3}{2} = P_0(x) + 5P_2(x)$ using eq. (2.26)

§2.14 Solving inhomogeneous differential equations

This can be thought of as the general case of Fourier series discussed previously.

Consider the problem

$$\mathcal{L}y = f(x) \equiv w(x)F(x) \quad (2.27)$$

on $x \in [a, b]$ assuming homogeneous boundary conditions. Given eigenfunctions $y_n(x)$ satisfying $\mathcal{L}y_n = \lambda_n w y_n$, we wish to expand this solution as (recall section 1.10)

$$y(x) = \sum_n c_n y_n(x)$$

and

$$F(x) = \sum_n a_n y_n(x)$$

where a_n are known and c_n are unknown. Using eq. (2.17):

$$a_n = \frac{\int_a^b w F y_n dx}{\int_a^b w y_n^2 dx}$$

Substituting,

$$\mathcal{L}y = \mathcal{L} \sum_n c_n y_n = w \sum_n c_n \lambda_n y_n = w \sum_n a_n y_n$$

By orthogonality,

$$c_n \lambda_n = a_n \implies c_n = \frac{a_n}{\lambda_n}$$

In particular,

$$y(x) = \sum_{n=1}^{\infty} \frac{a_n}{\lambda_n} y_n(x) \quad (2.28)$$

(assuming $\lambda_n \neq 0, \forall n$).

We can further generalise; we can permit a driving force, which often induces a linear response term $\tilde{\lambda}wy$.

$$\mathcal{L}y - \tilde{\lambda}wy = f(x) \quad (2.29)$$

where $\tilde{\lambda}$ is fixed. The solution eq. (2.28) becomes

$$y(x) = \sum_{n=1}^{\infty} \frac{a_n}{\lambda_n - \tilde{\lambda}} y_n(x) \quad (2.30)$$

(again $\tilde{\lambda} \neq \lambda_n, \forall n$).

§2.15 Integral solutions and Green's function

Recall eq. (2.28)

$$y(x) = \sum_{n=1}^{\infty} \frac{a_n}{\lambda_n} y_n(x) = \sum_n \frac{y_n(x)}{\lambda_n N_n} \int_a^b w(\xi) F(\xi) y_n(\xi) d\xi \text{ by eq. (2.17)}$$

where

$$N_n = \int w y_n^2 dx$$

This then gives

$$\begin{aligned} y(x) &= \int_a^b \underbrace{\sum_{n=1}^{\infty} \frac{y_n(x) y_n(\xi)}{\lambda_n N_n}}_{G(x, \xi)} \underbrace{w(\xi) F(\xi)}_{f(\xi)} d\xi \\ &= \int_a^b G(x; \xi) f(\xi) d\xi \end{aligned} \quad (2.31)$$

where

$$G(x, \xi) = \sum_{n=1}^{\infty} \frac{y_n(x) y_n(\xi)}{\lambda_n N_n}$$

is the eigenfunction expansion of the Green's function. Note that the Green's function does not depend on f , but only on \mathcal{L} and the boundary conditions. In this sense, it acts like an inverse operator

$$\mathcal{L}^{-1} \equiv \int d\xi G(x, \xi)$$

analogously to how $Ax = b \implies x = A^{-1}b$ for matrix equations.

Part II

PDEs on Bounded Domains

§3 The Wave Equation

§3.1 Waves on an elastic string

Consider a small displacement $y(x, t)$ on a stretched string with fixed ends at $x = 0$ and $x = L$, that is, with boundary conditions

$$y(0, t) = y(L, t) = 0. \quad (3.1)$$

and initial conditions

$$y(x, 0) = p(x), \quad \frac{\partial y}{\partial t}(x, 0) = q(x) \quad (3.2)$$

We derive the equation of motion governing the motion of the string by balancing forces on a string segment $(x, x + \delta x)$ and take the limit as $\delta x \rightarrow 0$.

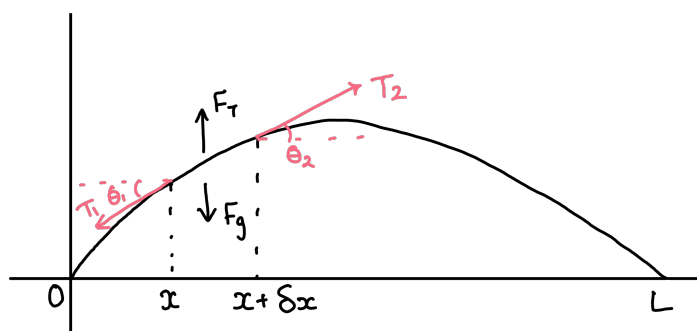

Let T_1 be the tension force acting to the left at angle θ_1 from the horizontal. Analogously, let T_2 be the rightwards tension force at angle θ_2 . We assume at any point on the string that $\left| \frac{\partial y}{\partial x} \right| \ll 1$, so the angles of the forces, θ_1, θ_2 are small. In the x dimension,

$$T_1 \cos \theta_1 = T_2 \cos \theta_2 \implies T_1 \approx T_2 = T \text{ by small angle approximation}$$

So the tension T is a constant independent of x up to an error of order $O\left(\left|\frac{\partial y}{\partial x}\right|^2\right)$. In the y dimension, since the θ are small,

$$F_T = T_2 \sin \theta_2 - T_1 \sin \theta_1 \approx T \left(\frac{\partial y}{\partial x} \Big|_{x+\delta x} - \frac{\partial y}{\partial x} \Big|_x \right) \approx T \frac{\partial^2 y}{\partial x^2} \delta x$$

By $F = ma$,

$$F_T + F_g = (\mu \delta x) \frac{\partial^2 y}{\partial t^2} = T \frac{\partial^2 y}{\partial x^2} \delta x - g\mu \delta x$$

where F_g is the gravitational force and μ is the mass per unit length (linear mass density). We define the wave speed as

$$c = \sqrt{\frac{T}{\mu}} \text{ (a constant)}$$

and find

$$\frac{\partial^2 y}{\partial t^2} = \frac{T}{\mu} \frac{\partial^2 y}{\partial x^2} - g = c^2 \frac{\partial^2 y}{\partial x^2} - g \quad (3.3)$$

We often assume gravity is negligible to produce the pure wave equation

$$\frac{1}{c^2} \frac{\partial^2 y}{\partial t^2} = \frac{\partial^2 y}{\partial x^2}. \quad (3.4)$$

The 1D wave equation is then $\ddot{y} = c^2 y''$.

§3.2 Separation of variables

We wish to solve the wave equation eq. (3.4) subject to boundary conditions eq. (3.1) and initial conditions eq. (3.2). Consider a possible solution of separable form (ansatz):

$$y(x, t) = X(x)T(t) \quad (3.5)$$

Substituting into the wave equation eq. (3.4),

$$\frac{1}{c^2} \ddot{y} = y'' \implies \frac{1}{c^2} X \ddot{T} = X'' T.$$

Then

$$\frac{1}{c^2} \frac{\ddot{T}}{T} = \frac{X''}{X}$$

However, $\frac{\ddot{T}}{T}$ depends only on t and $\frac{X''}{X}$ depends only on x . Thus, both sides must be equal to some *separation constant* $-\lambda$.

$$\frac{1}{c^2} \frac{\ddot{T}}{T} = \frac{X''}{X} = -\lambda$$

Hence,

$$X'' + \lambda X = 0 \quad (3.6)$$

$$\ddot{T} + \lambda c^2 T = 0. \quad (3.7)$$

§3.3 Boundary conditions and normal modes

We will begin by first solving the spatial ODE eq. (3.6). One of $\lambda > 0$, $\lambda < 0$, $\lambda = 0$ must be true. The boundary conditions eq. (3.1) restrict the possible λ .

1. First, suppose $\lambda < 0$. Take $\chi^2 = -\lambda$. Then,

$$X(x) = Ae^{\chi x} + Be^{-\chi x} = \tilde{A} \cosh(\chi x) + \tilde{B} \sinh(\chi x).$$

The boundary conditions are $x(0) = x(L) = 0$, so only the trivial solution is possible: $\tilde{A} = \tilde{B} = 0$.

2. Now, suppose $\lambda = 0$. Then

$$X(x) = Ax + B.$$

Again, the boundary conditions impose $A = B = 0$ giving only the trivial solution.

3. Finally, the last possibility is $\lambda > 0$.

$$X(x) = A \cos(\sqrt{\lambda}x) + B \sin(\sqrt{\lambda}x)$$

The boundary conditions give

$$A = 0; \quad B \sin(\sqrt{\lambda}L) = 0 \implies \sqrt{\lambda}L = n\pi.$$

The following are the eigenfunctions and eigenvalues.

$$X_n(x) = B_n \sin \frac{n\pi x}{L}; \quad \lambda_n = \left(\frac{n\pi}{L}\right)^2 \quad (n > 0) \quad (3.8)$$

These are also called the **normal modes** of the system because the spatial shape in x does not change in time, but the amplitude may vary.

The fundamental mode is the lowest frequency of vibration, given by

$$n = 1 \implies \lambda_1 = \frac{\pi^2}{L^2}$$

The second mode is the first overtone, and is given by



$$n = 2 \implies \lambda_2 = \frac{4\pi^2}{L^2}$$

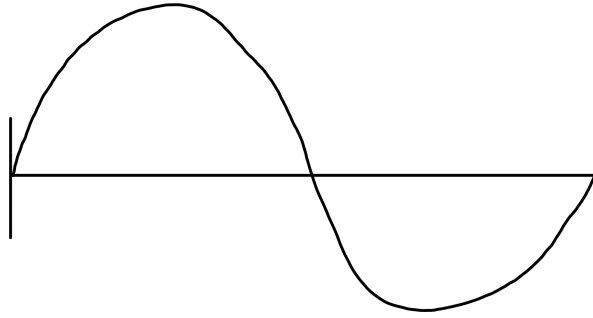

§3.4 Initial conditions and temporal solutions

Substituting λ_n into the time ODE eq. (3.7),

$$\ddot{T} + \frac{n^2\pi^2c^2}{L^2}T = 0.$$

Hence,

$$T_n(t) = C_n \cos \frac{n\pi ct}{L} + D_n \sin \frac{n\pi ct}{L}. \quad (3.9)$$

Therefore, a specific solution of the wave equation, eq. (3.4), satisfying the boundary conditions, eq. (3.1), is (absorbing the B_n into the C_n, D_n):

$$y_n(x, t) = T_n(t)X_n(x) = \left(C_n \cos \frac{n\pi ct}{L} + D_n \sin \frac{n\pi ct}{L} \right) \sin \frac{n\pi x}{L}$$

Exercise 3.1. Verify it's a solution.

Since the wave equation eq. (3.4) is linear (and b.c.s eq. (3.1) are homogenous) we can add the solutions (the y_n) together to find **general string solution**

$$y(x, t) = \sum_{n=1}^{\infty} \left(C_n \cos \frac{n\pi ct}{L} + D_n \sin \frac{n\pi ct}{L} \right) \sin \frac{n\pi x}{L}. \quad (3.10)$$

By construction, this $y(x, t)$ satisfies the boundary conditions, so now we can impose the initial conditions eq. (3.2):

$$y(x, 0) = p(x) = \sum_{n=1}^{\infty} C_n \sin \frac{n\pi x}{L}$$

We can find the C_n using standard Fourier series techniques eq. (1.12), since this is exactly a half-range sine series. Further,

$$\frac{\partial y(x, 0)}{\partial t} = q(x) = \sum_{n=1}^{\infty} \frac{n\pi c}{L} D_n \sin \frac{n\pi x}{L}$$

Again we can solve for the D_n in a similar way. Using eq. (1.12):

$$\begin{aligned} C_n &= \frac{2}{L} \int_0^L p(x) \sin \frac{n\pi x}{L} dx \\ D_n &= \frac{2}{n\pi c} \int_0^L q(x) \sin \frac{n\pi x}{L} dx \end{aligned} \quad (3.11)$$

Hence eq. (3.11) is the solution to eq. (3.4) satisfying eqs. (3.1) and (3.2).

Example 3.1

Consider the initial condition of a see-saw wave parametrised by ξ , and let $L = 1$. This can be visualised as plucking the string at position ξ .

$$y(x, 0) = p(x) = \begin{cases} x(1 - \xi) & 0 \leq x < \xi \\ \xi(1 - x) & \xi \leq x < 1 \end{cases}$$

We also define

$$\frac{\partial y(x, 0)}{\partial t} = q(x) = 0$$

The Fourier series eq. (1.8) for p is given by

$$C_n = \frac{2 \sin n\pi\xi}{(n\pi)^2}; \quad D_n = 0$$

Hence the solution to the wave equation is

$$y(x, t) = \sum_{n=1}^{\infty} \frac{2}{(n\pi)^2} \sin n\pi\xi \sin n\pi x \cos n\pi ct$$

Take $\xi = \frac{1}{2}$, $C_{2m} = 0$, $C_{2m-1} = \frac{2(-1)^{m+1}}{((2m-1)\pi)^2}$ (odd only), e.g. Guitar has $\frac{1}{4} \leq \xi \leq \frac{1}{3}$, Violin $\xi \approx \frac{1}{7}$.

Solution in characteristic coordinates

Recall sine/cosine summation identities (before eq. (1.1)) which means our general solution eq. (3.10) becomes

$$\begin{aligned} y(x, t) &= \frac{1}{2} \sum_{n=1}^{\infty} \left[C_n \sin \frac{n\pi}{L}(x - ct) + D_n \cos \frac{n\pi}{L}(x - ct) + C_n \sin \frac{n\pi}{L}(x + ct) + D_n \cos \frac{n\pi}{L}(x + ct) \right] \\ &\equiv f(x - ct) + g(x + ct) \end{aligned} \quad (3.12)$$

The standing wave solution eq. (3.10) is made up of a right-moving wave (along characteristic $x - ct = \eta$, η a constant) and a left-moving wave ($x + ct = \xi$, ξ a constant) i.e. a general solution with arbitrary f, g (see later).

Special case: $q(x) = 0$ in eq. (3.1) $\implies f = g = \frac{1}{2}D$ at $t = 0$.

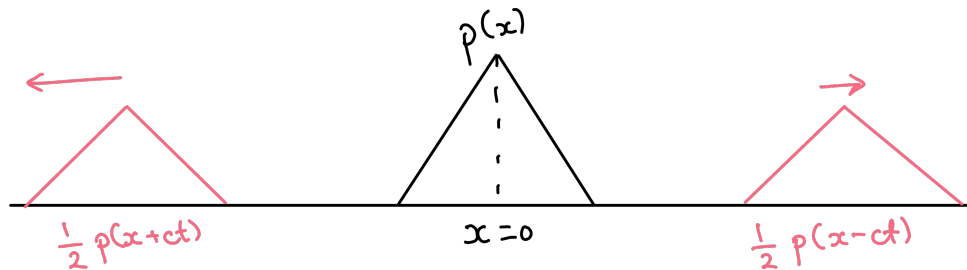

§3.5 Separation of variables methodology

A general strategy for solving higher-dimensional partial differential equations is as follows.

1. Obtain a linear PDE system, using boundary and initial conditions.
2. Separate variables to yield decoupled ODEs.
3. Impose homogeneous boundary conditions to find eigenvalues and eigenfunctions.
4. Use these eigenvalues (constants of separation) to find the eigenfunctions in the other variables.
5. Sum over the products of separable solutions to find the general series solution.
6. Determine coefficients for this series using the initial conditions.

§3.6 Energy of oscillations

A vibrating string has kinetic energy due to its motion.

$$\text{Kinetic energy} = \frac{1}{2}\mu \int_0^L \left(\frac{\partial y}{\partial t} \right)^2 dx$$

It has potential energy due to stretching by Δx given by

$$\text{Potential energy} = T\Delta x = T \int_c^T \left(\underbrace{\sqrt{1 + \left(\frac{\partial y}{\partial x}\right)^2}}_{\text{arc length } s} - 1 \right) dx \approx \frac{1}{2}T \int_0^L \left(\frac{\partial y}{\partial x}\right)^2 dx$$

assuming that the disturbances on the string are small, that is, $\left|\frac{\partial y}{\partial x}\right| \ll 1$. The total energy on the string, given $c^2 = T/\mu$, is given by

$$E = \frac{1}{2}\mu \int_0^L \left[\left(\frac{\partial y}{\partial t}\right)^2 + c^2 \left(\frac{\partial y}{\partial x}\right)^2 \right] dx \quad (3.13)$$

Substituting the solution eq. (3.10), using the orthogonality conditions eq. (1.1),

$$\begin{aligned} E &= \frac{1}{2}\mu \sum_{n=1}^{\infty} \int_0^L \left[\left(-\frac{n\pi c}{L} C_n \sin \frac{n\pi ct}{L} + \frac{n\pi c}{L} D_n \cos \frac{n\pi ct}{L} \right)^2 \sin^2 \frac{n\pi x}{L} \right. \\ &\quad \left. + c^2 \left(C_n \cos \frac{n\pi ct}{L} + D_n \sin \frac{n\pi ct}{L} \right)^2 \frac{n^2\pi^2}{L^2} \cos^2 \frac{n\pi x}{L} \right] dx \\ &= \frac{1}{4}\mu \sum_{n=1}^{\infty} \frac{n^2\pi^2 c^2}{L} (C_n^2 + D_n^2) \end{aligned} \quad (3.14)$$

which is an analogous result to Parseval's theorem. This is true since

$$\int_0^L \cos^2 \frac{n\pi x}{L} dx = \frac{L}{2}$$

and $\cos^2 + \sin^2 = 1$. We can think of this energy as the sum over all the normal modes of the energy in that specific mode. Note that this quantity is constant over time (no dissipation).

§3.7 Wave reflection and transmission

Recall the travelling wave solution eq. (3.12). The travelling wave has left-moving and right-moving modes. A **simple harmonic** travelling wave is

$$y = \text{Re} \left[A e^{i\omega(t-x/c)} \right] = A \cos [\omega(t - x/c) + \varphi]$$

where the phase φ is equal to $\arg A$, and the wavelength λ is $2\pi c/\omega$. In further discussion, we assume only the real part is used.

Consider a density discontinuity on the string at $x = 0$ with the following properties.

$$\mu = \begin{cases} \mu_- & \text{for } x < 0 \\ \mu_+ & \text{for } x > 0 \end{cases} \implies c = \begin{cases} c_- = \sqrt{\frac{T}{\mu_-}} & \text{for } x < 0 \\ c_+ = \sqrt{\frac{T}{\mu_+}} & \text{for } x > 0 \end{cases}$$

assuming a constant tension T . As a wave from the negative direction approaches the discontinuity, some of the wave will be reflected, given by $Be^{i\omega(t+x/c_-)}$, and some of the wave will be transmitted, given by $De^{i\omega(t-x/c_+)}$. The boundary conditions at $x = 0$ are

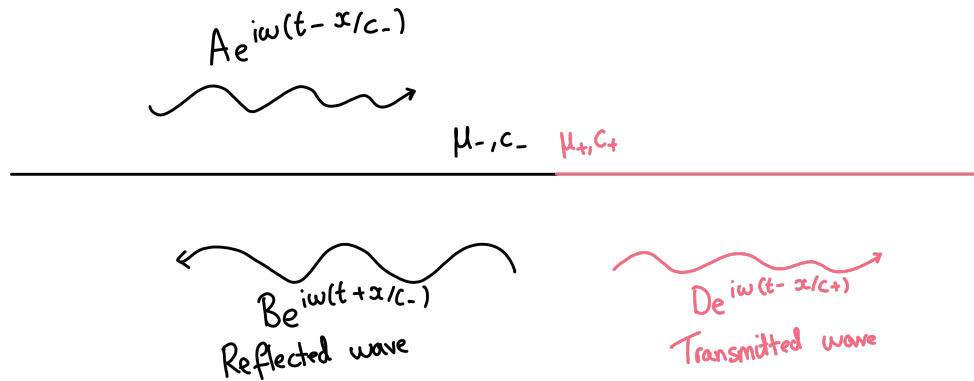

1. y is continuous for all t (the string does not break), so

$$A + B = D \quad (*)$$

2. The forces balance, $T \frac{\partial y}{\partial x} \Big|_{x=0^-} = T \frac{\partial y}{\partial x} \Big|_{x=0^+}$ which means $\frac{\partial y}{\partial x}$ must be continuous for all t . This gives

$$\frac{-i\omega A}{c_-} + \frac{i\omega B}{c_-} = \frac{-i\omega D}{c_+} \quad (\dagger)$$

We can eliminate B from $(*)$ by subtracting $\frac{c_-}{i\omega}(\dagger)$.

$$2A = D + D \frac{c_-}{c_+} = \frac{D}{c_+}(c_+ + c_-)$$

Hence, given A , we have the solution for the transmitted amplitude and reflected amplitude to be

$$D = \frac{2c_+}{c_- + c_+} A; \quad B = \frac{c_+ - c_-}{c_- + c_+} A \quad (3.16)$$

In general A, B, D are complex, hence different phase shifts are possible.

There are a number of limiting cases, for example

1. If $c_- = c_+$ we have $D = A$ and $B = 0$ so we have full transmission and no reflection.
2. (Dirichlet boundary conditions) If $\frac{\mu_+}{\mu_-} \rightarrow \infty$, this models a fixed end at $x = 0$. We have $\frac{c_+}{c_-} \rightarrow 0$ giving $D = 0$ and $B = -A$. Notice that the reflection has occurred with opposite phase, $\varphi = \pi$.
3. (Neumann boundary conditions) Consider $\frac{\mu_+}{\mu_-} \rightarrow 0$, this models a free end. Then $\frac{c_+}{c_-} \rightarrow \infty$ giving $D = 2A, B = A$. This gives total reflection but with the same phase.

§3.8 Wave equation in 2D plane polar coordinates

Consider the two-dimensional wave equation for $u(r, \theta, t)$ given by

$$\frac{1}{c^2} \frac{\partial^2 u}{\partial t^2} = \nabla^2 u \quad (3.17)$$

with boundary conditions at $r = 1$ on a unit disc given by

$$u(1, \theta, t) = 0 \quad (\text{fixed rim}) \quad (3.18)$$

and initial conditions for $t = 0$ given by

$$u(r, \theta, 0) = \varphi(r, \theta); \quad \frac{\partial u}{\partial t} = \psi(r, \theta) \quad (3.19)$$

§3.8.1 Temporal Separation

Suppose that this equation is separable. First, let us consider temporal separation. Suppose that

$$u(r, \theta, t) = T(t)V(r, \theta) \quad (3.20)$$

Then substitute into eq. (3.17)

$$\ddot{T} + \lambda c^2 T = 0 \quad (3.21)$$

$$\nabla^2 V + \lambda V = 0 \quad (3.22)$$

In plane polar coordinates, we can write the spatial equation eq. (3.22) as

$$\frac{\partial^2 V}{\partial r^2} + \frac{1}{r} \frac{\partial V}{\partial r} + \frac{1}{r^2} \frac{\partial^2 V}{\partial \theta^2} + \lambda V = 0$$

§3.8.2 Spatial Separation

We will perform another separation, supposing

$$V(r, \theta) = R(r)\Theta(\theta).$$

Substitute into eq. (3.22)

$$\Theta'' + \mu\Theta = 0 \quad (3.23)$$

$$r^2 R'' + rR' + (\lambda r^2 - \mu)R = 0 \quad (3.24)$$

where λ, μ are the separation constants.

§3.8.3 Polar Solution

The polar solution is constrained by periodicity $\Theta(0) = \Theta(2\pi)$, since we are working on a disc. We also consider only $\mu > 0$. The eigenvalue is then given by $\mu = m^2$, where $m \in \mathbb{N} \cup \{0\}$.

$$\Theta_m(\theta) = A_m \cos m\theta + B_m \sin m\theta \quad (3.25)$$

Or, in complex exponential form,

$$\Theta_m(\theta) = C_m e^{im\theta}; \quad m \in \mathbb{Z}$$

§3.9 Radial Equations

We can solve the radial equation eq. (3.24) (in the previous subsection) by converting it first into Sturm-Liouville form eq. (2.7), which can be accomplished by dividing by r with $\mu = m^2$.

$$\frac{d}{dr}(rR') - \frac{m^2}{r}R = -\lambda rR \quad (0 \leq r \leq 1) \quad (3.26)$$

where $p(r) = r$, $q(r) = \frac{m^2}{r}$, $w(r) = r$, with self-adjoint boundary conditions with $R(1) = 0$. We will require R is bounded at $R(0)$, and since $p(0) = 0$ there is a regular singular point at $r = 0$.

§3.9.1 Bessel's equation

This particular equation for R is known as Bessel's equation. We will first substitute $z \equiv \sqrt{\lambda}r$ in eq. (3.26), then we find the usual form of Bessel's equation⁴,

$$z^2 \frac{d^2 R}{dz^2} + z \frac{dR}{dz} + (z^2 - m^2)R = 0 \quad (3.27)$$

§3.9.2 Frobenius Solution

We can use the method of Frobenius by substituting the following power series:

$$R = z^p \sum_{n=0}^{\infty} a_n z^n$$

⁴May also be written as $(zR')' + (z - m^2/z)R = 0$

to find

$$\sum_{n=0}^{\infty} \left[a_n(n+p)(n+p-1)z^{n+p} + (n+p)z^{n+p} + z^{n+p+2} + m^2 z^{n+p} \right] = 0$$

Equating powers of z , we can find the indicial equation

$$p^2 - m^2 = 0 \implies p = m, -m$$

The regular solution, given by $p = m$, has recursion relation

$$(n+m)^2 a_n + a_{n-2} - m^2 a_n = 0$$

which gives

$$a_n = \frac{-1}{n(n+2m)} a_{n-2}$$

Hence, we can find

$$a_{2n} = a_0 \frac{(-1)^n}{2^{2n} n! (n+m)(n+m-1) \dots (m+1)}$$

If, by convention, we let

$$a_0 = \frac{1}{2^m m!}$$

we can then write the *Bessel function of the first kind* by

$$J_m(z) = \left(\frac{z}{2}\right)^m \sum_{n=0}^{\infty} \frac{(-1)^n}{n!(n+m)!} \left(\frac{z}{2}\right)^{2n} \quad (3.28)$$

Exercise 3.2. Use $y = \sqrt{z}R$ in Bessel's eqn eq. (3.27) to find $y'' + y(1 + \frac{1}{4z} - \frac{m^2}{z^2})$. So, as $z \rightarrow \infty$, $y'' = -y$ so we have solns $R = \frac{1}{\sqrt{z}}(A \cos z + B \sin z)$.

Also works for $m = \mu$ ($\mu \notin \mathbb{Z}$) if $(n+m)! \rightarrow \Gamma(n+m+1)$. Second soln with $p = -m$ (integer) is the Neuman function (Bessel function of second kind).

$$Y_m(z) = \lim_{\mu \rightarrow m} \frac{J_\mu \cos(\mu\pi) - J_{-\mu}(z)}{\sin \mu\pi}$$

Exercise 3.3. Use eq. (3.28) to show that $\frac{d}{dz}(z^m J_m(z)) = z^m J_{m-1}(z)$ and hence

$$J'_m(z) + \frac{m}{z} J_m(z) = J_{m-1}(z) \quad (3.29)$$

Repeat with z^{-m} to find recursion relations

$$\begin{aligned} J_{m-1}(z) + J_{m+1}(z) &= \frac{2m}{z} J_m(z) \\ J_{m-1}(z) - J_{m+1}(z) &= 2J'_m(z) \end{aligned} \quad (3.30)$$

§3.10 Asymptotic behaviour of Bessel functions

If z is small, the leading-order behaviour of $J_m(z)$ is

$$\begin{aligned}
 J_0(z) &\approx 1 \\
 J_m(z) &\approx \frac{1}{m!} \left(\frac{z}{2}\right)^m \\
 Y_0(z) &\rightarrow \frac{2}{\pi} \ln\left(\frac{z}{2}\right) \\
 Y_m(z) &\rightarrow -\frac{(m-1)!}{\pi} \left(\frac{2}{z}\right)^m
 \end{aligned} \tag{3.31}$$

Now, let us consider large z . In this case, the function becomes oscillatory;

$$\begin{aligned}
 J_m(z) &\approx \sqrt{\frac{2}{\pi z}} \cos\left(z - \frac{m\pi}{2} - \frac{\pi}{4}\right) \\
 Y_m(z) &\approx \sqrt{\frac{2}{\pi z}} \sin\left(z - \frac{m\pi}{2} - \frac{\pi}{4}\right)
 \end{aligned} \tag{3.32}$$

§3.11 Zeroes of Bessel functions $J_m(z)$

We can see from the asymptotic behaviour that there are infinitely many zeroes of the Bessel functions of the first kind as $z \rightarrow \infty$. We define j_{mn} to be the n th zero of J_m , for $z > 0$. Approximately using eq. (3.32),

$$\cos\left(z - \frac{m\pi}{2} - \frac{\pi}{4}\right) = 0 \implies z - \frac{m\pi}{2} - \frac{\pi}{4} = n\pi - \frac{\pi}{2} \quad (\text{modal point})$$

Hence

$$z \approx n\pi + \frac{m\pi}{2} - \frac{\pi}{4} \equiv \tilde{j}_{mn}$$

Non-examinable

Accuracy,

$$\left| \frac{j_{mn} - \tilde{j}_{mn}}{j_{mn}} \right| < \frac{0.1}{n} \text{ for } n > \frac{m^2}{2}. \tag{3.33}$$

For $J_0(z)$ actual values are $J_{01} = 2.405$, $J_{02} = 5.520$, $J_{03} = 8.653$, $J_{0n} = n\pi - \frac{\pi}{4}$ (precision $\approx 1\%/n$).

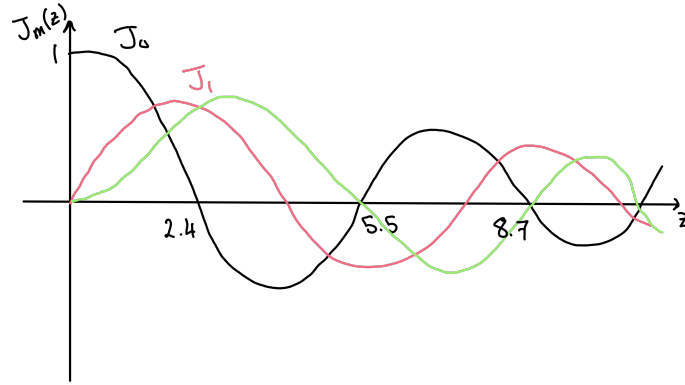

§3.12 Solving the vibrating drum

Recall that the radial solutions to eq. (3.26) become

$$R_m(z) = R_m(\sqrt{\lambda}x) = AJ_m(\sqrt{\lambda}x) + BY_m(\sqrt{\lambda}x)$$

Imposing the boundary condition of boundedness at $r = 0$, we must have $B = 0$ by eq. (3.31). Further imposing $r = 1$ and $R = 0$ gives $J_m(\sqrt{\lambda}) = 0$. These zeroes occur at $j_{mn} \approx n\pi + \frac{m\pi}{2} - \frac{\pi}{4}$. Hence, the eigenvalues must be

$$\lambda = j_{mn}^2. \quad (3.34)$$

Therefore, the spatial solution with the polar mode eq. (3.26) is

$$\begin{aligned} V_{mn}(r, \theta) &= \Theta_m(\theta)R_{mn}(\sqrt{\lambda_{mn}}r) \\ &= (A_{mn} \cos m\theta + B_{mn} \sin m\theta)J_m(j_{mn}r) \end{aligned} \quad (3.35)$$

The temporal solution eq. (3.21) is

$$\ddot{T} = -\lambda c^2 T \implies T_{mn}(t) = \cos(j_{mn}ct), \sin(j_{mn}ct)$$

Combining everything together, the full solution to eq. (3.17) is

$$\begin{aligned} u(r, \theta, t) &= \sum_{n=1}^{\infty} J_0(j_{0n}r)(A_{0n} \cos j_{0n}ct + C_{0n} \sin j_{0n}ct) \\ &+ \sum_{m=1}^{\infty} \sum_{n=1}^{\infty} J_m(j_{mn}r)(A_{mn} \cos m\theta + B_{mn} \sin m\theta) \cos j_{mn}ct \\ &+ \sum_{m=1}^{\infty} \sum_{n=1}^{\infty} J_m(j_{mn}r)(C_{mn} \cos m\theta + D_{mn} \sin m\theta) \sin j_{mn}ct \end{aligned} \quad (3.36)$$

Now, we impose the initial conditions eq. (3.19) at $t = 0$

$$u(r, \theta, 0) = \varphi(r, \theta) = \sum_{m=0}^{\infty} \sum_{n=1}^{\infty} J_m(j_{mn}r)(A_{mn} \cos m\theta + B_{mn} \sin m\theta) \quad (3.37)$$

and

$$\frac{\partial u}{\partial t}(r, \theta, 0) = \psi(r, \theta) = \sum_{m=0}^{\infty} \sum_{n=1}^{\infty} j_{mn} c J_m(j_{mn}r)(C_{mn} \cos m\theta + D_{mn} \sin m\theta)$$

We need to find the coefficients by multiplying by J_m, \cos, \sin and using the orthogonality relations (eqs. (1.1) to (1.3) and Sheet 1, Q8), which are

$$\int_0^1 J_m(j_{mn}r) J_m(j_{mk}r) r dr = \frac{1}{2} [J'_m(j_{mn})]^2 \delta_{nk} \quad (3.38)$$

$$= \frac{1}{2} [J_{m+1}(j_{mn})]^2 \delta_{nk} \quad (3.39)$$

by using a recursion relation of the Bessel functions. We can then integrate to obtain the coefficients A_{mn} .

$$\int_0^{2\pi} d\theta \cos p\theta \int_0^1 r dr J_p(j_{pq}r) \varphi(r, \theta) = \frac{\pi}{2} [J_{p+1}(j_{pq})]^2 A_{pq}$$

where the $\frac{\pi}{2}$ coefficient is 2π for $p = 0$.

Exercise 3.4. Find the analogous results for the B_{mn}, C_{mn}, D_{mn} .

Example 3.2

Consider an initial radial profile $u(r, \theta, 0) = \varphi(r) = 1 - r^2$. Then, $m = 0, B_{mn} = 0$ for all m and $A_{mn} = 0$ for all $m \neq n$. Then

$$\frac{\partial u}{\partial t}(r, 0, 0) = 0$$

hence $C_{mn}, D_{mn} = 0$. We just now need to find

$$A_{0n} = \frac{2}{J_1(j_{0n})^2} \int_0^1 J_0(j_{0n}r)(1-r)^2 r dr = \frac{2}{J_1(j_{0n})^2} \frac{J_2(j_{0n})}{j_{0n}^2} \approx \frac{J_2(j_{0n})}{n} \text{ as } n \rightarrow \infty$$

Proving this is left as an exercise using eqs. (3.29) and (3.30). Then the approximate solution is

$$u(r, \theta, t) = \sum_{n=1}^{\infty} A_{0n} J_0(j_{0n}r) \cos j_{0n}ct$$

The fundamental frequency is $\omega_d = j_{01} c \frac{2}{d} \approx 4.8 \frac{c}{d}$ where d is the diameter of the drum. Comparing this to a string with length d , this has a fundamental frequency of $\omega_s = \frac{\pi c}{d} \approx 0.77 \omega_d$.

§4 Diffusion equation

§4.1 Diffusion equation derivation with Fourier's law

Fourier's law for heat flow is

$$q = -k\nabla\theta \quad (4.1)$$

where q is the heat flux, k the thermal conductivity and θ is the temperature. In a volume V , the overall heat energy Q is given by

$$Q = \int_V c_V \rho \theta \, dV \quad (4.2)$$

where c_V is the specific heat of the material, ρ is the mass density. The rate of change due to heat flow is

$$\frac{dQ}{dt} = \int_V c_V \rho \frac{\partial\theta}{\partial t} \, dV \quad (*)$$

We will integrate eq. (4.1) over the surface $S = \partial V$, giving

$$-\frac{dQ}{dt} = \int_S q \cdot \hat{n} \, dS$$

The negative sign is due to the normals facing outwards. This is exactly

$$-\frac{dQ}{dt} = \int_S (-k\nabla\theta) \cdot \hat{n} \, dS = \int_V -k\nabla^2\theta \, dV \quad (\dagger)$$

Equating these two forms ((*) and (†)) for $\frac{dQ}{dt}$, we find

$$\int_V (c_V \rho \frac{\partial\theta}{\partial t} - k\nabla^2\theta) \, dV = 0$$

Since V was arbitrary, the integrand must be zero. So we have

$$\frac{\partial\theta}{\partial t} - \frac{k}{c_V \rho} \nabla^2\theta = 0$$

Let $D = \frac{k}{c_V \rho}$ be the diffusion constant. Then we have the diffusion equation

$$\frac{\partial\theta}{\partial t} - D\nabla^2\theta = 0 \quad (4.3)$$

§4.2 Diffusion equation derivation with statistical dynamics

We can derive this equation in another way, using statistical dynamics. Gas particles diffuse by scattering every fixed time step Δt with probability density function $p(\xi)$ of moving by a displacement ξ . On average, we have

$$\mathbb{E}[\xi] = \int p(\xi)\xi \, d\xi = 0$$

since there is no bias the direction in which any given particle is travelling. Suppose that the probability density function after $N\Delta t$ time is described by $P_{N\Delta t}(x)$. Then, for the next time step,

$$P_{(N+1)\Delta t}(x) = \int_{-\infty}^{\infty} p(\xi)P_{N\Delta t}(x - \xi) \, d\xi$$

Using the Taylor expansion,

$$\begin{aligned} P_{(N+1)\Delta t}(x) &\approx \int_{-\infty}^{\infty} p(\xi) \left[P_{N\Delta t}(x) + P'_{N\Delta t}(x)(-\xi) + P''_{N\Delta t}(x)\frac{\xi^2}{2} + \dots \right] d\xi \\ &\approx P_{N\Delta t}(x) - P'_{N\Delta t}(x)\mathbb{E}[\xi] + P''_{N\Delta t}(x)\frac{\mathbb{E}[\xi^2]}{2} + \dots \\ &\approx P_{N\Delta t}(x) + P''_{N\Delta t}(x)\frac{\mathbb{E}[\xi^2]}{2} + \dots \end{aligned}$$

since $\int p(\xi) \, d\xi = 1$. Identifying $P_{N\Delta t}(x) = P(x, N\Delta t)$, we can write

$$P(x, (N+1)\Delta t) - P(x, N\Delta t) = \frac{\partial^2}{\partial x^2} P(x, N\Delta t) \frac{\mathbb{E}[\xi^2]}{2}$$

Assuming that the variance $\mathbb{E}[\xi^2]$ ⁵ is equal to $2D\Delta t$, then for small Δt , we find

$$\frac{\partial P}{\partial t} = D \frac{\partial^2 P}{\partial x^2} \quad (4.4)$$

which is exactly the diffusion equation.

§4.3 Similarity solutions

The characteristic relation between the variance and time suggests that we seek solutions with a dimensionless parameter. If we can find a change of variables of the form $\theta(\eta) = \theta(x, t)$, then it will likely be easier to solve. Consider

$$\eta \equiv \frac{x}{2\sqrt{Dt}} \quad (4.5)$$

⁵ $\text{Var } X = \mathbb{E}[X^2] - \mathbb{E}[X]^2$ and $\mathbb{E}[X] = 0$.

Then changing variables in eq. (4.3),

$$\frac{\partial \theta}{\partial t} = \frac{\partial \eta}{\partial t} \frac{\partial \theta}{\partial \eta} = \frac{-1}{2} \frac{x}{\sqrt{Dt^{3/2}}} \theta' = \frac{-1}{2} \frac{\eta}{t} \theta'$$

and

$$D \frac{\partial^2 \theta}{\partial x^2} = D \frac{\partial}{\partial x} \left(\frac{\partial \eta}{\partial x} \frac{\partial \theta}{\partial \eta} \right) = D \frac{\partial}{\partial x} \left(\frac{1}{2\sqrt{Dt}} \theta' \right) = \frac{D}{4Dt} \theta'' = \frac{1}{4t} \theta''$$

Equating,

$$\theta'' = -2\eta \theta' \quad (4.6)$$

Let $\psi = \theta'$. Then

$$\frac{\psi'}{\psi} = -2\eta \implies \ln \psi = -\eta^2 + \text{constant}$$

Then, choosing a constant of $c \frac{2}{\sqrt{\pi}}$,

$$\psi = c \frac{2}{\sqrt{\pi}} e^{-\eta^2} \implies \theta(\eta) = c \frac{2}{\sqrt{\pi}} \int_0^\eta e^{-u^2} du = c \operatorname{erf}(\eta) = c \operatorname{erf} \left(\frac{x}{2\sqrt{Dt}} \right) \quad (4.7)$$

where

$$\operatorname{erf}(z) = \frac{2}{\sqrt{\pi}} \int_0^z e^{-u^2} du$$

This describes discontinuous initial conditions that spread over time.

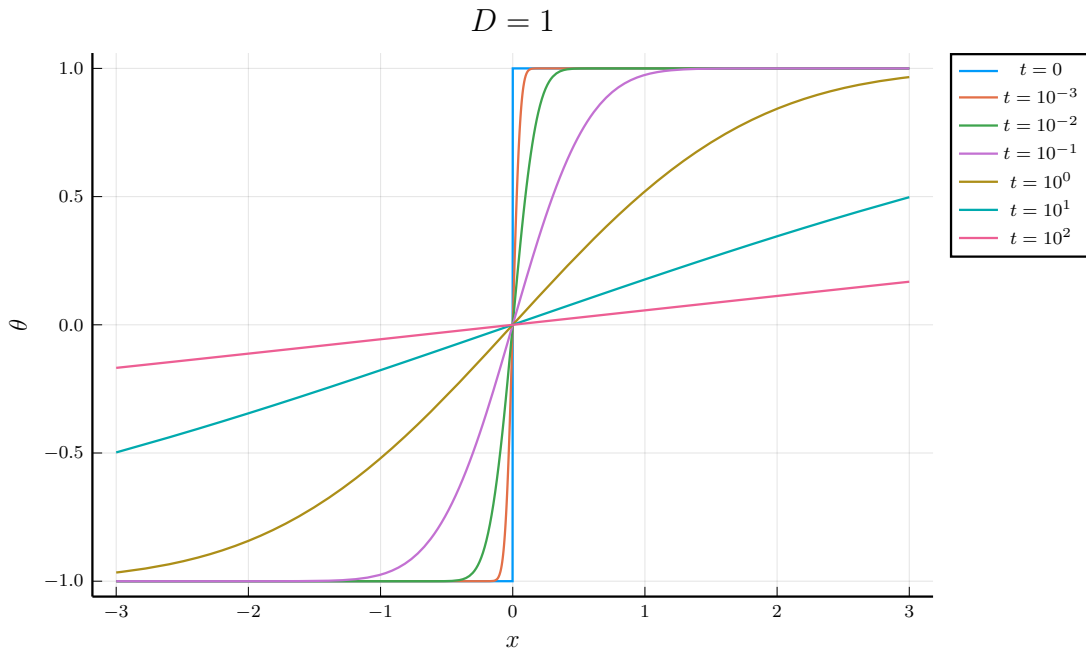

§4.4 Heat conduction in a finite bar

Suppose we have a bar of length $2L$ with $-L \leq x \leq L$ and initial temperature

$$\theta(x, 0) = H(x) = \begin{cases} 1 & \text{if } 0 \leq x \leq L \\ 0 & \text{if } -L \leq x < 0 \end{cases} \quad (4.8)$$

with boundary conditions

$$\theta(L, t) = 1, \quad \theta(-L, t) = 0. \quad (4.9)$$

§4.4.1 Transforming boundary conditions

Currently the boundary conditions eq. (4.9) are not homogeneous, so Sturm-Liouville theory cannot be used directly. If we can identify a steady-state solution (time-independent) that reflects the late-time behaviour, then we can turn it into a homogeneous set of boundary conditions. We will try a solution of the form

$$\theta_s(x) = Ax + B$$

since this certainly satisfies the diffusion equation. To satisfy the boundary conditions eq. (4.9),

$$A = \frac{1}{2L}; \quad B = \frac{1}{2}$$

Hence we have a solution

$$\theta_s = \frac{x + L}{2L} \quad (4.10)$$

We will subtract this solution from our original equation for θ , giving

$$\hat{\theta}(x, t) = \theta(x, t) - \theta_s(x)$$

with homogeneous boundary conditions

$$\hat{\theta}(-L, t) = \hat{\theta}(L, t) = 0$$

and initial conditions

$$\hat{\theta}(x, 0) = H(x) - \frac{x + L}{2L} \quad (4.11)$$

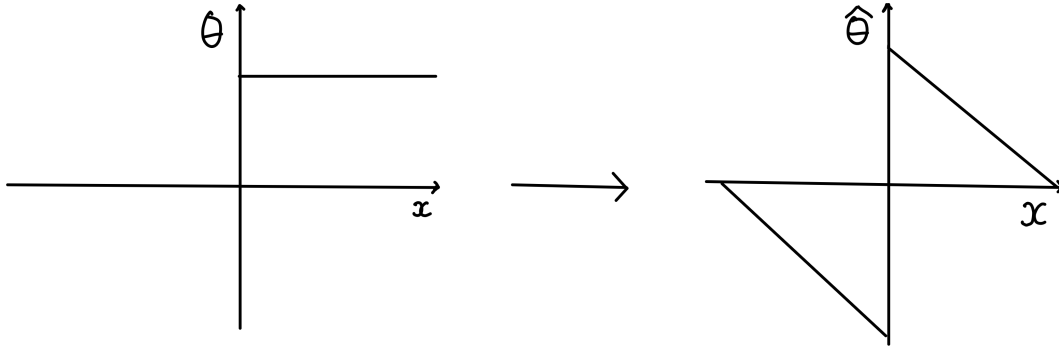

§4.4.2 Separation of variables

We will now separate variables in the usual way. We will consider the ansatz

$$\hat{\theta}(x, t) = X(x)T(t) \implies X'' = -\lambda X; \dot{T} = -D\lambda T \quad (4.12)$$

The boundary conditions imply $\lambda > 0$ and give the Fourier modes $X(x) = A \cos \sqrt{\lambda}x + B \sin \sqrt{\lambda}x$. For $\cos \sqrt{\lambda}L = 0$, we require $\sqrt{\lambda}L = \frac{m\pi}{2}$ for m odd. Also, $\sin \sqrt{\lambda}L = 0$ gives $\sqrt{\lambda}L = \frac{n\pi}{2}$ for n even. Since $\hat{\theta}$ is odd due to our initial conditions, we can take

$$X_n = B_n \sin \frac{n\pi x}{L}; \quad \lambda_n = \frac{n^2\pi^2}{L^2}$$

Substituting λ_n into eq. (4.12), $\dot{T} = -D\lambda T$, we have

$$T_n(t) = C_n \exp\left(-\frac{Dn^2\pi^2}{L^2}t\right).$$

In general, the solution is

$$\hat{\theta}(x, t) = \sum_{n=1}^{\infty} b_n \sin \frac{n\pi x}{L} \exp\left(-\frac{Dn^2\pi^2}{L^2}t\right) \quad (4.13)$$

§4.5 Particular solution to diffusion equation

At $t = 0$, we have a pure Fourier sine series. We can then impose the initial conditions eq. (4.11), to give

$$b_n = \frac{1}{L} \int_{-L}^L \hat{\varphi}(x, 0) \sin \frac{n\pi x}{L} dx$$

where

$$\hat{\varphi}(x, 0) = H(x) - \frac{x+L}{2L}$$

Hence, we can use the half-range sine series and find

$$b_n = \underbrace{\frac{2}{L} \int_0^L \left(H(x) - \frac{1}{2} \right) \sin \frac{n\pi x}{L} dx}_{\text{square wave}/2, \text{ eq. (1.7)}} - \underbrace{\frac{2}{L} \int_0^L \frac{x}{2L} \sin \frac{n\pi x}{L} dx}_{\text{sawtooth}/2L, \text{ eq. (1.6)}}$$

which gives

$$b_n = \frac{2}{(2m-1)\pi} - \frac{(-1)^{n+1}}{n\pi}$$

where $n = 2m - 1$, and the first term vanishes for n even. For n odd or even, we find the same result

$$b_n = \frac{1}{n\pi}$$

Hence

$$\hat{\theta}(x, t) = \sum_{n=1}^{\infty} \frac{1}{n\pi} \sin \frac{n\pi x}{L} \exp \left(-D \frac{n^2 \pi^2}{L^2} t \right)$$

For the inhomogeneous boundary conditions,

$$\theta(x, t) = \frac{x+L}{2L} + \hat{\theta}(x, t) \tag{4.14}$$

The similarity solution $\frac{1}{2} \left(1 + \operatorname{erf} \left(\frac{x}{2\sqrt{Dt}} \right) \right)$, eq. (4.7), is a good fit for early t (excellent for $t \leq 1$), but it does not necessarily satisfy the boundary conditions, so for large t it is a bad approximation.

Plot with $L = 1$ and $D = 1$ insertpicture

§5 The Laplace Equation

§5.1 Laplace's equation

Laplace's equation is

$$\nabla^2 \varphi = 0 \quad (5.1)$$

This equation describes (among others) steady-state heat flow, potential theory $F = -\nabla\varphi$, and incompressible fluid flow $v = \nabla\varphi$. The equation eq. (5.1) is solved typically on a domain D , where boundary conditions are specified often on the boundary surface. The Dirichlet boundary conditions fix φ on the boundary surface ∂D . The Neumann boundary conditions fix $\hat{n} \cdot \nabla\varphi$ on ∂D .

§5.2 Laplace's equation in three-dimensional Cartesian coordinates

In \mathbb{R}^3 with Cartesian coordinates, Laplace's equation becomes

$$\frac{\partial^2 \varphi}{\partial x^2} + \frac{\partial^2 \varphi}{\partial y^2} + \frac{\partial^2 \varphi}{\partial z^2} = 0 \quad (5.2)$$

We seek separable solutions in the usual way:

$$\varphi(x, y, z) = X(x)Y(y)Z(z)$$

Substituting,

$$X''YZ + XY''Z + XYZ'' = 0$$

Dividing by XYZ as usual,

$$\begin{aligned} \frac{X''}{X} &= \frac{-Y''}{Y} - \frac{Z''}{Z} = -\lambda_\ell \quad (\text{constant}) \\ \frac{Y''}{Y} &= \frac{-Z''}{Z} - \frac{X''}{X} = -\lambda_m \quad (\text{constant}) \\ \frac{Z''}{Z} &= \frac{-X''}{X} - \frac{Y''}{Y} = -\lambda_n = \lambda_\ell + \lambda_m \end{aligned}$$

From the eigenmodes, our general solution will be of the form

$$\varphi(x, y, z) = \sum_{\ell, m, n} a_{\ell mn} X_\ell(x) Y_m(y) Z_n(z) \quad (5.4)$$

Example 5.1 (Steady heat conduction)

Consider steady ($\frac{\partial \varphi}{\partial t} = 0$) heat flow^a in a semi-infinite rectangular bar, with boundary conditions $\varphi = 0$ at $x = 0, x = a, y = 0$ and $y = b$; and $\varphi = 1$ at $z = 0$ and $\varphi \rightarrow 0$ as $z \rightarrow \infty$.

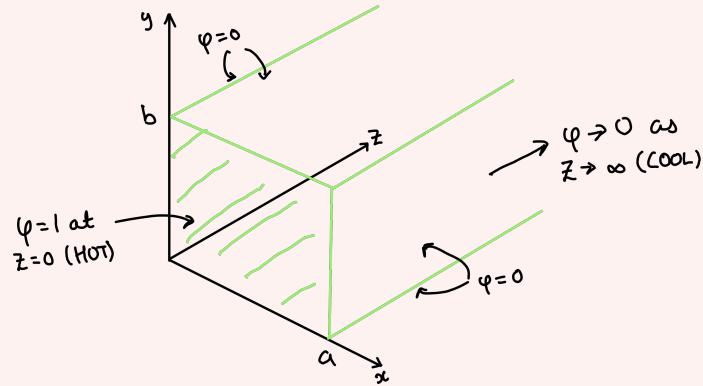

We will solve for each eigenmode successively. First, consider $X'' = -\lambda_\ell X$ with $X(0) = X(a) = 0$. This gives

$$\lambda_\ell = \frac{\ell^2 \pi^2}{a^2}; \quad X_\ell = \sin \frac{\ell \pi x}{a}$$

where $\ell > 0, \ell \in \mathbb{N}$. By symmetry,

$$\lambda_m = \frac{m^2 \pi^2}{b^2}; \quad Y_m = \sin \frac{m \pi y}{b}$$

For the z mode,

$$Z'' = -\lambda_n Z = (\lambda_\ell + \lambda_m) Z = \pi^2 \left(\frac{\ell^2}{a^2} + \frac{m^2}{b^2} \right) Z$$

Since $\varphi \rightarrow 0$ as $z \rightarrow \infty$, the growing exponentials must vanish. Therefore,

$$Z_{\ell m} = \exp \left[- \left(\frac{\ell^2}{a^2} + \frac{m^2}{b^2} \right)^{1/2} \pi z \right]$$

Thus the general solution eq. (5.4) becomes

$$\varphi(x, y, z) = \sum_{\ell, m} a_{\ell m} \sin \frac{\ell \pi x}{a} \sin \frac{m \pi y}{b} \exp \left[- \left(\frac{\ell^2}{a^2} + \frac{m^2}{b^2} \right)^{1/2} \pi z \right]$$

Now, we will fix $a_{\ell m}$ using $\varphi(x, y, 0) = 1$ using the Fourier sine series eq. (1.12).

$$a_{\ell m} = \frac{2}{b} \int_0^b \frac{2}{a} \int_0^a \underbrace{1 \sin \frac{\ell \pi x}{a}}_{\text{square wave}} \underbrace{\sin \frac{m \pi y}{b}}_{\text{square wave}} dx dy$$

So only the odd terms remain, giving

$$a_{\ell m} = \frac{4a}{a(2k-1)\pi} \cdot \frac{4b}{b(2p-1)\pi}$$

where $\ell = 2k - 1$ is odd and $m = 2p - 1$ is odd. Simplifying,

$$a_{\ell m} = \frac{16}{\pi^2 \ell m} \quad \text{for } \ell, m \text{ odd}$$

So the heat flow solution is

$$\varphi(x, y, z) = \sum_{\ell, m \text{ odd}} \frac{16}{\pi^2 \ell m} \sin \frac{\ell \pi x}{a} \sin \frac{\ell \pi y}{b} \exp \left[- \left(\frac{\ell^2}{a^2} + \frac{m^2}{b^2} \right)^{1/2} \pi z \right]$$

As z increases, every contribution but the lowest mode will be very small. So low ℓ, m dominate the solution.

Cross sectionals: insertpicture

^ai.e. eq. (4.3) with $\frac{\partial \varphi}{\partial t} = 0$ gives eq. (5.1)

§5.3 Laplace's equation in plane polar coordinates

In plane polar coordinates, Laplace's equation becomes

$$\frac{1}{r} \frac{\partial}{\partial r} \left(r \frac{\partial \varphi}{\partial r} \right) + \frac{1}{r^2} \frac{\partial^2 \varphi}{\partial \theta^2} = 0 \quad (5.6)$$

Consider a separable form of the answer, given by

$$\varphi(r, \theta) = R(r)\Theta(\theta)$$

We then have

$$\Theta'' + \mu\Theta = 0; \quad r(rR')' - \mu R = 0$$

§5.3.1 Polar equation

The polar equation can be solved easily by considering periodic boundary conditions. This gives $\mu = m^2$ and the eigenmodes as in eq. (3.25)

$$\Theta_m(\theta) = \cos m\theta, \sin m\theta$$

§5.3.2 Radial equation

The radial equation is *not* Bessel's equation, since there is no second separation constant. We simply have

$$r(rR')' - m^2R = 0 \quad (5.7)$$

We will try a power law solution, $R = \alpha r^\beta$. We find

$$\beta^2 - m^2 = 0 \implies \beta = \pm m$$

So the eigenfunctions are

$$R_m(r) = r^m, r^{-m}$$

which is one regular solution at the origin and one singular solution. In the case $m = 0$, we have

$$(rR')' = 0 \implies rR' = \text{constant} \implies R = \log r$$

So

$$R_0(r) = \text{constant or } \log r$$

The general solution is therefore

$$\varphi(r, \theta) = \frac{a_0}{2} + c_0 \log r + \sum_{m=1}^{\infty} (a_m \cos m\theta + b_m \sin m\theta)r^m + \sum_{m=1}^{\infty} (c_m \cos m\theta + d_m \sin m\theta)r^{-m} \quad (5.8)$$

Example 5.2 (Soap Film on a Unit Disc)

insertpicture

Consider a soap film on a unit disc. We wish to solve Laplace's equation eq. (5.6) with a vertically distorted circular wire of radius $r = 1$ with boundary conditions $\varphi(1, \theta) = f(\theta)$. The z displacement of the wire produces the $f(\theta)$ term. We wish to find $\varphi(r, \theta)$ for $r < 1$, assuming regularity at $r = 0$. Then, $c_m = d_m = 0$ and so

eq. (5.8) becomes

$$\varphi(r, \theta) = \frac{a_0}{2} + \sum_{m=1}^{\infty} (a_m \cos m\theta + b_m \sin m\theta)r^m$$

At $r = 1$,

$$\varphi(1, \theta) = f(\theta) = \frac{a_0}{2} + \sum_{m=1}^{\infty} (a_m \cos m\theta + b_m \sin m\theta)$$

which is exactly the Fourier series. Thus by eq. (1.5),

$$a_m = \frac{1}{\pi} \int_0^{2\pi} f(\theta) \cos m\theta \, d\theta; \quad b_m = \frac{1}{\pi} \int_0^{2\pi} f(\theta) \sin m\theta \, d\theta$$

We can see from the equation that high harmonics are confined to have effects only near $r = 1$.

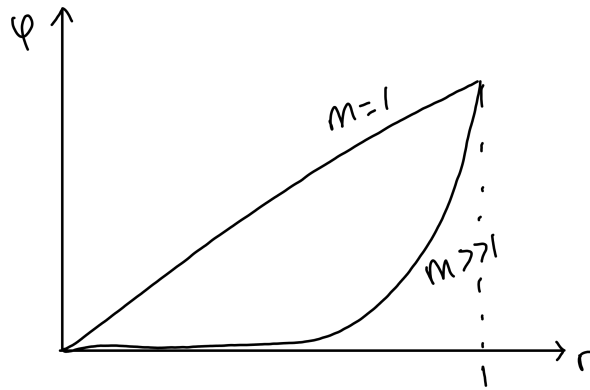

§5.4 Laplace's equation in cylindrical polar coordinates

In cylindrical coordinates,

$$\frac{1}{r} \frac{\partial}{\partial r} \left(r \frac{\partial \varphi}{\partial r} \right) + \frac{1}{r^2} \frac{\partial^2 \varphi}{\partial \theta^2} + \frac{\partial^2 \varphi}{\partial z^2} = 0 \quad (5.9)$$

With $\varphi = R(r)\Theta(\theta)Z(z)$, we find

$$\Theta'' = -\mu\Theta; \quad Z'' = \lambda Z; \quad r(rR')' + (\lambda r^2 - \mu)R = 0$$

The polar equation can be easily solved (as before) by

$$\mu_m = m^2; \quad \Theta_m(\theta) = \cos m\theta, \sin m\theta$$

The radial equation is Bessel's equation eq. (3.26), giving solutions

$$R = J_m(kr), Y_m(kr)$$

Setting boundary conditions in the usual way, defining $R = 0$ at $r = a$ means that

$$J_m(ka) = 0 \implies k = \frac{j_{mn}^6}{a}$$

The radial solution is

$$R_{mn}(r) = J_m\left(\frac{j_{mn}}{a}r\right) \quad (5.10)$$

We have eliminated the Y_n term since we require $r = 0$ to give a finite φ and $Y_n \rightarrow -\infty$ as $r \rightarrow 0$.

Finally, the z equation gives

$$Z'' = k^2 Z \implies Z = e^{-kz}, e^{kz}$$

We typically eliminate the e^{kz} mode due to boundary conditions, such as $Z \rightarrow 0$ as $z \rightarrow \infty$. The general solution is therefore

$$\varphi(r, \theta, z) = \sum_{m=0}^{\infty} \sum_{n=1}^{\infty} (a_{mn} \cos m\theta + b_{mn} \sin m\theta) J_m\left(\frac{j_{mn}}{a}r\right) e^{-\frac{j_{mn}z}{a}} \quad (5.11)$$

Exercise 5.1. Describe steady-state heat flow in a semi-infinite circular wire with b.c.s $\varphi = 0$ at $r = a$, $\varphi = T_0$ at $z = 0$ and $\varphi \rightarrow 0$ as $z \rightarrow \infty$. Use sections 3.9 and 5.1. Show that the soln is $\varphi(r, \theta, z) = \sum_{n=1}^{\infty} \frac{2T_0}{j_{0n}J_1(j_{0n})} J_0\left(\frac{j_{0n}}{a}r\right) e^{-\frac{j_{0n}z}{a}}$.

§5.5 Laplace's equation in spherical polar coordinates

Recall that

$$\begin{aligned} x &= r \sin \theta \cos \varphi \\ y &= r \sin \theta \sin \varphi \\ z &= r \cos \theta \\ dV &= r^2 \sin \theta \, dr \, d\theta \, d\varphi \end{aligned}$$

with $0 \leq r < \infty, 0 \leq \theta \leq \pi, 0 \leq \varphi < 2\pi$.

In spherical polar coordinates Laplace's equations eq. (5.1) becomes,

$$\frac{1}{r^2} \frac{\partial}{\partial r} \left(r^2 \frac{\partial \Phi}{\partial r} \right) + \frac{1}{r^2 \sin \theta} \frac{\partial}{\partial \theta} \left(\sin \theta \frac{\partial \Phi}{\partial \theta} \right) + \frac{1}{r^2 \sin^2 \theta} \frac{\partial^2 \Phi}{\partial \varphi^2} = 0 \quad (5.12)$$

We will consider the *axisymmetric case*; supposing that there is no φ dependence. We seek a separable solution of the form

$$\Phi(r, \theta) = R(r)\Theta(\theta)$$

which gives

$$(\sin \theta \Theta')' + \lambda \sin \theta \Theta = 0; \quad (r^2 R')' - \lambda R = 0 \quad (5.13)$$

§5.5.1 Polar (Legendere) equation

Consider the substitution $\theta \mapsto x$ with $x = \cos \theta$, $\frac{dx}{d\theta} = -\sin \theta$ in the polar equation. This gives $\frac{d\Theta}{d\theta} = -\sin \theta \frac{d\Theta}{dx}$ and hence

$$-\sin \theta \frac{d}{dx} \left[-\sin^2 \theta \frac{d\Theta}{dx} \right] + \lambda \sin \theta \Theta = 0 \implies \frac{d}{dx} \left[(1-x^2) \frac{d\Theta}{dx} \right] + \lambda \Theta = 0$$

This gives Legendre's equation eq. (2.21), so it has solutions of eigenvalues $\lambda_\ell = \ell(\ell+1)$ and eigenfunctions section 2.11

$$\Theta_\ell(\theta) = P_\ell(x) = P_\ell(\cos \theta) \quad (5.14)$$

§5.5.2 Radial equation

The radial equation then gives

$$(r^2 R')' - \ell(\ell+1)R = 0$$

We will seek power law solutions: $R = \alpha r^\beta$. This gives

$$\beta(\beta+1) - \ell(\ell+1) = 0 \implies \beta = \ell, \beta = -\ell - 1$$

Thus the radial eigenmodes are

$$R_\ell = r^\ell, r^{-\ell-1}$$

§5.6 General axisymmetric solution

Therefore the general axisymmetric solution for spherical polar coordinates is

$$\Phi(r, \theta) = \sum_{\ell=0}^{\infty} (a_\ell r^\ell + b_\ell r^{-\ell-1}) P_\ell(\cos \theta) \quad (5.15)$$

The a_ℓ, b_ℓ are determined by the boundary conditions. Orthogonality conditions for the P_ℓ can be used to determine coefficients (see eq. (2.24)).

Example 5.3

Consider a solution to Laplace's equation on the unit sphere with axisymmetric boundary conditions at $r = 1$ given by

$$\Phi(1, \theta) = f(\theta)$$

Given that we wish to find the interior solution, $b_n = 0$ by regularity. Then,

$$f(\theta) = \sum_{\ell=0}^{\infty} a_{\ell} P_{\ell}(\cos \theta)$$

By defining $f(\theta) = F(\cos \theta)$,

$$F(x) = \sum_{\ell=0}^{\infty} a_{\ell} P_{\ell}(x)$$

We can then find the coefficients in the usual way, given by eq. (2.25)

$$a_{\ell} = \frac{2\ell + 1}{2} \int_{-1}^1 F(x) P_{\ell}(x) dx.$$

Exercise 5.2. Show $f(\theta) = \sin^2 \theta$ yields a solution $\Phi(r, \theta) = \frac{2}{3}(1 - P_2(\cos \theta)r^2)$

§5.7 Generating function for Legendre polynomials

Consider a charge at $r_0 = (x, y, z) = (0, 0, 1)$. Then, the potential at a point P (represented by $r = (x, y, z)$) becomes

$$\begin{aligned} \Phi(r) &= \frac{1}{|r - r_0|} = \frac{1}{(x^2 + y^2 + (x - 1)^2)^{1/2}} \\ &= \frac{1}{\underbrace{(r^2(\sin^2 \varphi + \cos^2 \varphi) \sin^2 \theta + r^2 \cos^2 \theta - 2r \cos \theta + 1)}_{x^2 + y^2}} \text{ in spherical coordinates} \\ &= \frac{1}{(r^2 \sin^2 \theta + r^2 \cos^2 \theta - 2r \cos \theta + 1)^{1/2}} \\ &= \frac{1}{(r^2 - 2r \cos \theta + 1)^{1/2}} \\ &= \frac{1}{(r^2 - 2r\bar{x} + 1)^{1/2}} \end{aligned}$$

where $\bar{x} \equiv \cos \theta$. This function Φ is a solution to Laplace's equation where $r \neq r_0$.

Exercise 5.3. Verify $\Phi = \frac{1}{|r - r_0|}$ satisfies $\nabla^2 \Phi = 0$ where $r \neq r_0$.

Note that we can represent any axisymmetric solution eq. (5.12) as a sum of Legendre polynomials eq. (5.15) (with $b_n = 0$) for $r < 1$. Now,

$$\frac{1}{\sqrt{r^2 - 2rx + 1}} = \sum_{\ell=0}^{\infty} a_{\ell} P_{\ell}(x) r^{\ell}$$

With the normalisation condition for the Legendre polynomials $P_{\ell}(1) = 1$ at $x = 1$, we find

$$\frac{1}{1-r} = \sum_{\ell=0}^{\infty} a_{\ell} r^{\ell}$$

Using the geometric series expansion ($\frac{1}{1-r} = 1 + r + r^2 + \dots$), we arrive at $a_{\ell} = 1$. This gives

$$\frac{1}{\sqrt{r^2 - 2rx + 1}} = \sum_{\ell=0}^{\infty} P_{\ell}(x) r^{\ell} \quad (5.16)$$

which is the generating function for the Legendre polynomials. Expand LHS with binomial theorem to find $P_{\ell}(x)$ (coeff of r^{ℓ} th term). Use to obtain normalisation condition eq. (2.24) (Sheet 2, Q5).

Example 5.4 (Electric multipoles)

Consider charges along z -axis at $z = \pm a, 0$, viewed from $x \gg a$ with $\varphi \rightarrow 0$ as $r \rightarrow \infty$ (i.e. $a_n = 0$, singular part of expansion eq. (5.15)).

$\ell = 0$:

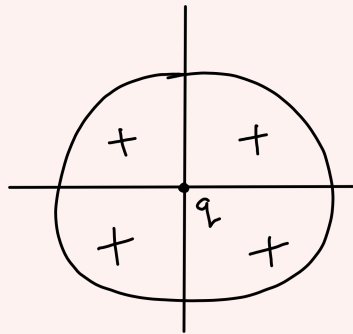

$\Phi \propto \frac{1}{r}$ - monopole field of point charge q .

$\ell = 1$:

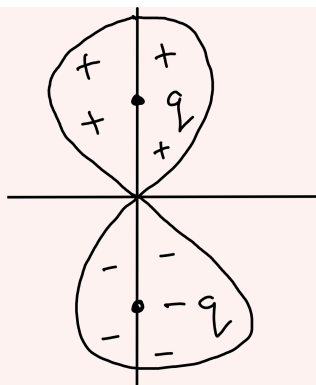

$\Phi \propto \frac{\cos \theta}{r^2}$ - dipole field for two opposite charges.

$\ell = 2$

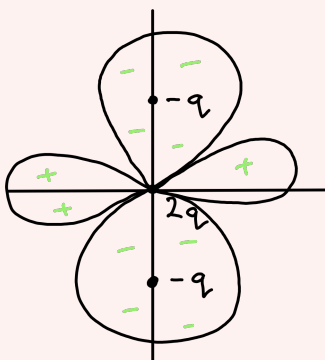

$\Phi \propto \frac{1}{2} \frac{3 \cos^2 \theta - 1}{r^3}$ quadrupole field.

Part III

Inhomogenous ODEs; Fourier Transforms

§6 Dirac delta function

Definition 6.1 (Dirac Delta Function)

We define a generalised function $\delta(x - \xi)$ such that

$$\begin{aligned}\delta(x - \xi) &= 0 \quad \forall x \neq \xi; \\ \int_{-\infty}^{\infty} \delta(x - \xi) dx &= 1.\end{aligned}\tag{6.1}$$

This acts as a linear operator $\int dx \delta(x - \xi)$ on some arbitrary function $f(x)$ to produce a number $f(\xi)$.

$$\int_{-\infty}^{\infty} dx \delta(x - \xi) f(x) = f(\xi)\tag{6.2}$$

This relationship holds provided that $f(x)$ is sufficiently 'well-behaved' at $x = \xi$ and $x \rightarrow \pm\infty$.

Note. • Strictly, the δ 'function' is classified as a distribution, not as a function. See lectures notes of Jozsa and Skinner section 6.1 for more details.

- For this reason, we will never use δ outside an integral, although such an integral may be implied.
- The δ function represents a unit point source (e.g. mass, charge) or an impulse.

§6.1 Some limiting approximations

A discrete approximation as $n \rightarrow \infty$ is $\delta_n = \begin{cases} 0 & x > \frac{1}{n} \\ \frac{n}{2} & |x| \leq \frac{1}{n} \\ 0 & x < -\frac{1}{n} \end{cases}$.

Continuous: We can approximate the δ function using a Gaussian approximation as $\varepsilon \rightarrow 0$.

$$\delta_\varepsilon(x) = \frac{1}{\varepsilon\sqrt{\pi}} \exp\left[-\frac{x^2}{\varepsilon^2}\right]\tag{6.3}$$

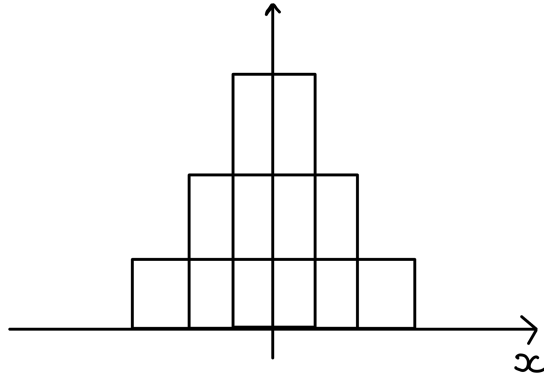

Figure 1: Discrete approximation

Therefore verifying eq. (6.2),

$$\int_{-\infty}^{\infty} f(x)\delta(x) dx = \lim_{\varepsilon \rightarrow 0} \int_{-\infty}^{\infty} \frac{1}{\varepsilon\sqrt{\pi}} \exp\left[-\frac{x^2}{\varepsilon^2}\right] f(x) dx$$

Let $y = \frac{x}{\varepsilon}$,

$$\begin{aligned} &= \lim_{\varepsilon \rightarrow 0} \int_{-\infty}^{\infty} \frac{1}{\sqrt{\pi}} \exp[-y^2] f(\varepsilon y) dy \\ &= \lim_{\varepsilon \rightarrow 0} \int_{-\infty}^{\infty} \frac{1}{\sqrt{\pi}} \exp[-y^2] [f(0) + \varepsilon y f'(0) + \dots] dy \\ &= f(0) \end{aligned}$$

for all 'well-behaved functions' f at $0, \pm\infty$ ⁷.

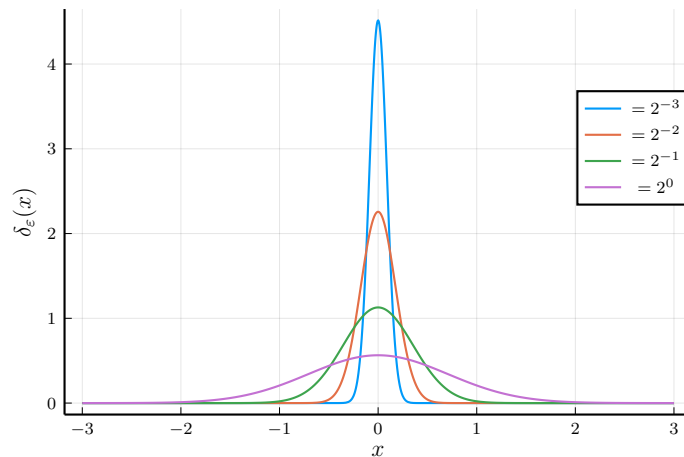

⁷Well behaved at 0 lets us Taylor expand and well behaved at $\pm\infty$ means it doesn't diverge faster than the Gaussian.

Further Examples We could alternatively use the Dirichlet kernel (as $n \rightarrow \infty$)

$$\delta_n(x) = \frac{\sin nx}{\pi x} = \frac{1}{2\pi} \int_{-n}^n e^{ikx} dk \quad (6.4)$$

or even

$$\delta_n(x) = \frac{n}{2} \operatorname{sech}^2 nx \quad (6.5)$$

§6.2 Integral and derivative of delta function

§6.2.1 Integral of $\delta(x)$

We define the Heaviside step function by

$$H(x) = \begin{cases} 1 & x \geq 0 \\ 0 & x < 0 \end{cases} \quad (6.6)$$

For $x \neq 0$, we have

$$H(x) = \int_{-\infty}^x \delta(t) dt \quad (6.7)$$

Thus,

$$\frac{d}{dx} H(x) = \delta(x)$$

where this identification takes place under an implied integral.

Exercise 6.1. Verify using eq. (6.5) $\delta(x) = \lim_{n \rightarrow \infty} \frac{n}{2} \operatorname{sech}^2 nx$ [You will find $\frac{1}{2}(\tanh nx + 1)$ which is an approximate step function. This also gives $H(0) = \frac{1}{2}$ (an alternative definition)].

§6.2.2 Derivative of $\delta(x)$

We define $\delta'(x)$ using integration by parts.

$$\begin{aligned} \int_{-\infty}^{\infty} \delta'(x - \xi) f(x) dx &= [\delta(x - \xi) f(x)]_{-\infty}^{\infty} - \int_{-\infty}^{\infty} \delta(x - \xi) f'(x) dx \\ &= - \int_{-\infty}^{\infty} \delta(x - \xi) f'(x) dx \\ \int_{-\infty}^{\infty} \delta'(x - \xi) f(x) dx &= -f'(\xi) \end{aligned} \quad (6.8)$$

This is valid for all f that are smooth at $x = \xi$.

Example 6.1

Consider the Gaussian approximation eq. (6.3):

$$\delta_\varepsilon(x) = \frac{1}{\varepsilon\sqrt{\pi}} \exp\left[-\frac{x^2}{\varepsilon^2}\right]$$

Then,

$$\delta'_\varepsilon(x) = \frac{-2x}{\varepsilon^3\sqrt{\pi}} \exp\left[-\frac{x^2}{\varepsilon^2}\right]$$

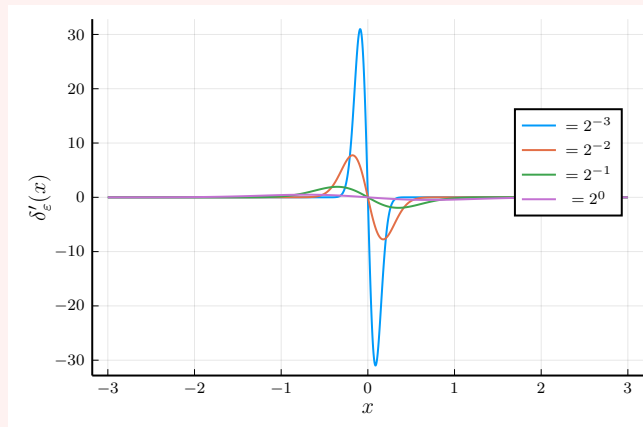

§6.3 Properties of delta function

§6.3.1 Sampling Property

Note that

$$\int_a^b f(x)\delta(x - \xi) dx = \begin{cases} f(\xi) & a < \xi < b \\ 0 & \text{otherwise} \end{cases} \quad (6.9)$$

So the δ function only 'samples' values within the integral range. This is known as the sampling property.

§6.3.2 Even Property

Let $u = -(x - \xi)$, and consider

$$\int_{-\infty}^{\infty} f(x)\delta(-(x - \xi)) dx = \int_{\infty}^{-\infty} f(\xi - u)\delta(u)(-du)$$

$$\begin{aligned}
&= \int_{-\infty}^{\infty} f(\xi - u)\delta(u) \, du \\
&= f(\xi)
\end{aligned}$$

Hence,

$$\int_{-\infty}^{\infty} f(x)\delta(-(x - \xi)) \, dx = \int_{-\infty}^{\infty} f(x)\delta(x - \xi) \, dx \quad (6.10)$$

This is called the even property.

§6.3.3 Scaling Property

Now, consider

$$\int_{-\infty}^{\infty} f(x)\delta(a(x - \xi)) \, dx = \frac{1}{|a|}f(\xi) \quad (6.11)$$

Exercise 6.2. Show this using $u = ax$ (noting integral limit order with $a < 0$).

§6.3.4 Advanced Scaling Property

Let $g(x)$ be a function with n isolated roots at x_1, \dots, x_n . Then, assuming $g'(x)$ does not vanish at the x_i ,

$$\delta(g(x)) = \sum_{i=1}^n \frac{\delta(x - x_i)}{|g'(x_i)|} \quad (6.12)$$

This is a generalisation of the above, known as the advanced scaling property.

Exercise 6.3. Show for g has 1 root at $x = x_i$.

Example 6.2

$$\begin{aligned}
I &= \int_{-\infty}^{\infty} f(x)\delta(x^2 - 1) \, dx \\
&= \int_{1-\varepsilon}^{1+\varepsilon} f(x) \frac{\delta(x - 1)}{|2x|} \, dx + \int_{-1-\varepsilon}^{-1+\varepsilon} f(x) \frac{\delta(x + 1)}{|2x|} \, dx \\
&= \frac{1}{2}(f(1) + f(-1)).
\end{aligned}$$

§6.3.5 Isolation Property

Now, if $g(x)$ is continuous at $x = 0$, then

$$g(x)\delta(x) = g(0)\delta(x) \quad (6.13)$$

inside an integral.

Exercise 6.4. Evaluate and show $\int_0^\infty \delta'(x^2 - 1)x^2 dx = -\frac{1}{4}$ using $u = x^2 - 1$ and eq. (6.8) and eq. (6.12).

§6.4 Fourier series expansion of delta function

Consider a complex Fourier series expansion,

$$\delta(x) = \sum_{n=-\infty}^{\infty} c_n e^{in\pi x/L}; \quad c_n = \frac{1}{2L} \int_{-L}^L \delta(x) e^{-in\pi x/L} dx = \frac{1}{2L}$$

Hence,

$$\delta(x) = \frac{1}{2L} \sum_{n=-\infty}^{\infty} e^{in\pi x/L} \quad (6.14)$$

Let $f(x)$ be a function, so $f(x) = \sum_{n=-\infty}^{\infty} d_n e^{in\pi x/L}$. Then (using section 2.2), their inner product is given by

$$\int_{-L}^L f^*(x)\delta(x) dx = \frac{1}{2L} \sum_{n=-\infty}^{\infty} d_n \int_{-L}^L e^{in\pi x/L} e^{in\pi x/L} dx = \sum_{n=-\infty}^{\infty} d_n = f(0)$$

The Fourier expansion of the δ function can be extended periodically to the whole real line. This infinite set of δ functions is known as the **Dirac comb**, given by

$$\sum_{m=-\infty}^{\infty} \delta(x - 2mL) = \frac{1}{2L} \sum_{n=-\infty}^{\infty} e^{in\pi x/L}$$

§6.5 Arbitrary eigenfunction expansion of delta function

In general, suppose

$$\delta(x - \xi) = \sum_{n=1}^{\infty} a_n y_n(x), \quad a \leq x \leq b$$

with coefficients, eq. (2.17)

$$\begin{aligned} a_n &= \frac{\int_a^b w(x)y_n(x)\delta(x-\xi) dx}{\int_a^b w(x)y_n(x)^2 dx} \\ &= \frac{w(\xi)y_n(\xi)}{\int_a^b w(x)y_n(x)^2 dx} \\ &= w_n(\xi)Y_n(\xi) \text{ for unit norm eq. (2.18)} \end{aligned}$$

Then,

$$\delta(x-\xi) = w(\xi) \sum_{n=1}^{\infty} Y_n(\xi)Y_n(x) = w(x) \sum_{n=1}^{\infty} Y_n(\xi)Y_n(x)$$

since $\frac{w(x)}{w(\xi)}\delta(x-\xi) = \delta(x-\xi)$ by eq. (6.13). Hence,

$$\delta(x-\xi) = w(x) \sum_{n=1}^{\infty} \frac{y_n(\xi)y_n(x)}{\mathcal{N}_n} \quad (6.15)$$

where $\mathcal{N}_n = \int_a^b w y_n^2 dx$ is a normalisation factor.

Example 6.3

Consider a Fourier series for $y(0) = y(1) = 0$, with $y_n(x) = \sin n\pi x$. From the sine series coefficient expression eq. (1.11),

$$\delta(x-\xi) = 2 \sum_{n=1}^{\infty} \sin n\pi\xi \sin n\pi x$$

where $0 < \xi < 1$.

- Exercise 6.5.** 1. Integrate both sides to show $\sum_{m=1}^{\infty} \frac{(-1)^{m+1}}{2m-1} = \frac{1}{4}$ when $\varepsilon = \frac{1}{2}$.
2. Integrate twice and compare with $G(x, \xi)$?? or eq. (2.31).

§7 Green's Functions

§7.1 Physical motivation: Static Forces on a String

Consider a massive static string with tension T and linear mass density μ , suspended between fixed ends ($L = 1$)

$$y(0) = y(1) = 0. \quad (7.1)$$

By resolving forces, we have the time independent form eq. (3.3)

$$T \frac{d^2 y}{dx^2} - \mu g = 0$$

We will solve the inhomogeneous ODE

$$-\frac{d^2 y}{dx^2} = f(x) \quad (7.2)$$

with $f(x) = -\frac{\mu g}{T}$ subject to eq. (7.1).

§7.1.1 Direct integration

This has been placed in Sturm-Liouville form. We can integrate directly and find eq. (7.2) gives

$$-y = -\frac{\mu g}{2T} x^2 + k_1 x + k_2$$

Imposing boundary conditions eq. (7.1),

$$y(x) = \left(-\frac{\mu g}{T}\right) \cdot \frac{1}{2} x(1-x) \quad (7.3)$$

§7.1.2 Superposition of point masses

Consider alternatively a solution obtained by solving the equation for a single point mass $\delta m = \mu \delta x$ suspended at $x = \xi_i$ on an very light string. We can then superimpose the solutions for each point mass to find the overall solution. For a single point mass, the solution is given by two straight lines from $(0, 0)$ and $(1, 0)$ to the point mass $(\xi_i, y_i(\xi_i))$. The angles of these straight lines from the horizontal are given by θ_1, θ_2 . Resolving in the y direction to find $y_i(\xi_i)$,

$$\begin{aligned} 0 &= T(\sin \theta_1 + \sin \theta_2) - \delta m g \\ &= T \left(\frac{-y_i}{\xi_i} + \frac{-y_i}{1 - \xi_i} \right) - \delta m g \end{aligned}$$

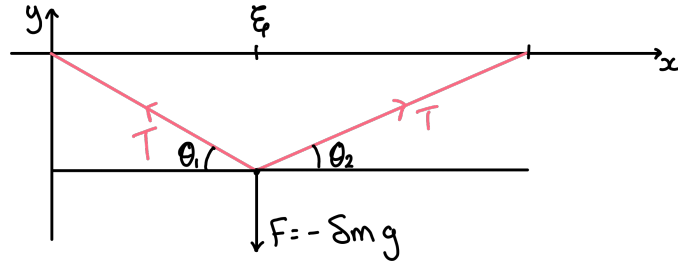

$$\begin{aligned} \therefore -T(y_i(1 - \xi_i) + y_i \xi_i) &= \delta m g \xi_i(1 - \xi_i) \\ \therefore y_i(\xi_i) &= \frac{-\delta m g}{T} \xi_i(1 - \xi_i) \end{aligned}$$

So the solution is

$$y_i(x) = \frac{-\delta m g}{T} \begin{cases} x(1 - \xi_i) & x < \xi_i \\ \xi_i(1 - x) & x > \xi_i \end{cases}$$

which is the generalised sawtooth. This can alternatively be written

$$y_i(x) = f_i(\xi)G(x, \xi) \quad (7.4)$$

where f_i is a source term, and $G(x, \xi)$ is the Green's function, the solution for a unit point source. Since the differential equation is linear, we can sum the solutions for N point masses, giving

$$y(x) = \sum_{i=1}^N f_i(\xi)G(x, \xi_i)$$

Taking a continuum limit,

$$f_i(\xi) = \frac{-\delta m g}{T} = \frac{-\mu \delta x g}{T} \equiv f(x) dx \implies f(x) = \frac{-\mu g}{T}$$

which gives ($x \mapsto \xi$)

$$y(x) = \int_0^1 f(\xi)G(x, \xi) d\xi \quad (7.5)$$

where we are integrating over all source positions. Substituting the Green's function,

$$\begin{aligned} y(x) &= \left(\frac{-\mu g}{T} \right) \left[\underbrace{\int_0^x \xi(1-x) d\xi}_{x > \xi} + \underbrace{\int_x^1 x(1-\xi) d\xi}_{x < \xi} \right] \\ &= \left(\frac{-\mu g}{T} \right) \left\{ \left[\frac{\xi^2}{2}(1-x) \right]_0^x + \left[x \left(\xi - \frac{\xi^2}{2} \right) \right]_x^1 \right\} \end{aligned}$$

$$\begin{aligned}
&= \left(\frac{-\mu g}{T} \right) \left(\frac{x^2}{2}(1-x) - 0 + \frac{x}{2} - x \left(x - \frac{x^2}{2} \right) \right) \\
&= \left(\frac{-\mu g}{T} \right) \cdot \frac{1}{2} x(1-x)
\end{aligned}$$

So we have found the correct solution in two ways; once by direct integration, and once by superimposing point solutions. In general, direct integration is not trivial, and Green's functions are useful in this case.

§7.2 Definition of Green's function

We wish to solve the inhomogeneous ODE eq. (2.21)

$$\mathcal{L}y \equiv \alpha(x)y'' + \beta(x)y' + \gamma(x)y = f(x) \quad (7.6)$$

on $a \leq x \leq b$, where $\alpha \neq 0$ and α, β, γ are continuous and bounded, taking homogeneous boundary conditions $y(a) = y(b) = 0$.

The Green's function for \mathcal{L} in this case is defined to be the solution for a unit point source at $x = \xi$. That is, $G(x, \xi)$ is the function that satisfies the boundary conditions and

$$\mathcal{L}G(x, \xi) = \delta(x - \xi) \quad (7.7)$$

so $G(a, \xi) = G(b, \xi) = 0$. Then, by linearity, the general solution is given by

$$y(x) = \int_a^b f(\xi)G(x, \xi) d\xi \quad (7.8)$$

where $y(x)$ satisfies the homogeneous boundary conditions. We can verify this by checking

$$\mathcal{L}y = \int_a^b \mathcal{L}_{(x)}G(x, \xi)f(\xi) d\xi = \int_a^b \delta(x - \xi)f(\xi) d\xi = f(x)$$

So the solution is given by the inverse operator

$$y = \mathcal{L}^{-1}f; \quad \mathcal{L}^{-1} = \int_a^b d\xi G(x, \xi)$$

§7.3 Defining properties (summary)

The Green's function splits into two parts;

$$G(x, \xi) = \begin{cases} G_1(x, \xi) & a \leq x < \xi \\ G_2(x, \xi) & \xi < x \leq b \end{cases} \quad (7.9)$$

1. Hom solns G solves homogenous equation $\forall x \neq \xi$ so

$$\mathcal{L}G_1 = \mathcal{L}G_2 = 0 \quad (7.10)$$

2. Hom b.c.s G satisfies the homogeneous boundary conditions, so

$$G_1(a, \xi) = 0, \quad G_2(b, \xi) = 0 \quad (7.11)$$

3. Continuity condition G must be continuous at $x = \xi$, hence

$$G_1(\xi, \xi) = G_2(\xi, \xi) \quad (7.12)$$

4. Jump condition There is a jump condition; the derivative of G is discontinuous at $x = \xi$. This satisfies

$$[G']_{\xi-}^{\xi+} = \left. \frac{dG_2}{dx} \right|_{x=\xi+} - \left. \frac{dG_1}{dx} \right|_{x=\xi-} = \frac{1}{\alpha(\xi)} \quad (7.13)$$

where $\alpha(x)$ is defined in eq. (7.6).

§7.4 Explicit form for Green's functions

We want to solve

$$\mathcal{L}G(x, \xi) = \delta(x - \xi)$$

on $a \leq x \leq b$, subject to homogeneous boundary conditions $G(a, \xi) = G(b, \xi) = 0$ (with $a < \xi < b$). The functions G_1, G_2 satisfy the homogeneous equation, so $\mathcal{L}G_i(x, \xi) = 0$.

§7.4.1 1 & 2, Solve hom eqn with hom b.cs

Suppose there exist two independent homogeneous solutions $y_1(x), y_2(x)$ to $\mathcal{L}y = 0$. Then, $G_1 = Ay_1 + By_2$, such that $Ay_1(a) + By_2(a) = 0$, which gives a constraint between A and B . This defines a complementary function $y_-(x)$ such that $y_-(a) = 0$. The general homogeneous solution with $G_1(a) = 0$ is

$$G_1 = Cy_- \quad (7.14)$$

C will be found later.

Similarly we can define y_+ as a linear combination of y_1, y_2 such that $y_+(b) = 0$.

$$G_2 = Dy_+ \quad (7.15)$$

§7.4.2 3. Why is G continuous at $x = \xi$?

Suppose G was discontinuous at $x = \xi$, so locally $G \propto H(x - \xi) + \dots$ eq. (6.7) which implies $G' \propto \delta(x - \xi)$ and $G'' \propto \delta'(x - \xi)$. So LHS $\mathcal{L}G \propto \alpha(x)\delta'(x - \xi) + \beta(x)\delta(x - \xi) + \gamma(x)H(x - \xi)$. But on RHS there is not $\delta'(x - \xi) \neq \delta(x - \xi) \nexists$. Hence, we have $[G]_{\xi_-}^{\xi^+} = 0$, so we require $G_1(\xi, \xi) = G_2(\xi, \xi)$ for continuity, hence

$$Cy_-(\xi) = Dy_+(\xi) \quad (7.16)$$

§7.4.3 4. Why the jump condition for G' at $x = \xi$

Integrate $\mathcal{L}G(x, \xi) = \delta(x - \xi)$ across $x = \xi$:

$$\begin{aligned} LHS &= \int_{\xi_-}^{\xi^+} \mathcal{L}G \, dx \\ &= \int_{\xi_-}^{\xi^+} \alpha G'' + \beta G' + \gamma G \, dx \end{aligned}$$

Integrate by parts

$$= \underbrace{\alpha(\xi)[G']_{\xi_-}^{\xi^+}}_{\text{by cty of } \alpha(x)} + (\beta - \alpha')[G]_{\xi_-}^{\xi^+} + \int_{\xi_-}^{\xi^+} (\gamma - \beta' + \alpha'')G \, dx$$

The latter two terms are 0 as $\xi^+ \rightarrow \xi_-$ by continuity of Green's function eq. (7.12).

$$RHS = \int_{\xi_-}^{\xi^+} \delta(x - \xi) \, dx = 1.$$

Thus $[G']_{\xi_-}^{\xi^+} = \frac{1}{\alpha(\xi)}$, we have

$$Dy'_+(\xi) - Cy'_-(\xi) = \frac{1}{\alpha(\xi)} \quad (7.17)$$

We can solve these equations eqs. (7.16) and (7.17) for C, D simultaneously to find

$$C(\xi) = \frac{y_+(\xi)}{\alpha(\xi)W(\xi)}; \quad D(\xi) = \frac{y_-(\xi)}{\alpha(\xi)W(\xi)} \quad (7.18)$$

where $W(\xi)$ is the Wronskian

$$W(\xi) = y_-(\xi)y'_+(\xi) - y_+(\xi)y'_-(\xi) \quad (7.19)$$

which is nonzero if y_-, y_+ are linearly independent. Hence,

$$G(x, \xi) = \begin{cases} \frac{y_-(x)y_+(\xi)}{\alpha(\xi)W(\xi)} & a \leq x \leq \xi \\ \frac{y_-(\xi)y_+(x)}{\alpha(\xi)W(\xi)} & \xi \leq x \leq b \end{cases} \quad (7.20)$$

§7.5 Solving boundary value problems

We know that the solution of $\mathcal{L}y = f$ eq. (7.6) with $y(a) = y(b) = 0$ is

$$y(x) = \int_a^b G(x, \xi) f(\xi) d\xi$$

We can split this into two intervals given that $G = G_1$ for $\xi > x$ and $G = G_2$ for $\xi < x$.

$$\begin{aligned} y(x) &= \int_a^x G_2(x, \xi) f(\xi) d\xi + \int_x^b G_1(x, \xi) f(\xi) d\xi \\ &= y_+(x) \int_a^x \frac{y_-(\xi) f(\xi)}{\alpha(\xi) W(\xi)} d\xi + y_-(x) \int_a^x \frac{y_+(\xi) f(\xi)}{\alpha(\xi) W(\xi)} d\xi \end{aligned} \quad (7.21)$$

Note. 1. Note that if \mathcal{L} is in Sturm-Liouville form, so $\beta = \alpha'$, then the denominator $\alpha(\xi)W(\xi)$ is a constant and G is symmetric; $G(x, \xi) = G(\xi, x)$.

Exercise 7.1. Show that $\frac{d}{dx}(\alpha(x)W(x)) = 0$ using $\beta = \alpha'$ and self-adjoint form eq. (2.10) $y_-\mathcal{L}y_+ - y_+\mathcal{L}y_-$.

- Often, by convention, we take $\alpha = 1$ (however Sturm-Liouville form typically takes $\alpha < 0$).
- Indefinite integrals \int_x in eq. (7.21) are particular integrals in general solution eq. (2.5).

Exercise 7.2. For $-y'' = f(x)$, $y(0) = y(1) = 0$ directly construct the Green's function eq. (7.4)

$$G(x, \xi) = \begin{cases} x(1 - \xi) & x \leq \xi \\ \xi(1 - x) & x > \xi \end{cases}$$

(i.e. using $y_{hom} = Ax + b$ and $\alpha = -1$).

Example 7.1

Consider $y'' - y = f(x)$ with $y(0) = y(1) = 0$. Let us construct $G(x, \xi)$.

1 & 2 Homogeneous solutions are $y_1 = e^x, y_2 = e^{-x}$. Imposing boundary conditions (by inspection),

$$G = \begin{cases} C \sinh x & 0 \leq x < \xi \\ D \sinh(1 - x) & \xi < x \leq b \end{cases}$$

3 Continuity at $x = \xi$ implies

$$C \sinh \xi = D \sinh(1 - \xi) \implies C = D \frac{\sinh(1 - \xi)}{\sinh \xi}$$

4 The jump condition is

$$-D \cosh(1 - \xi) - C \cosh \xi = 1$$

Hence,

$$\begin{aligned} -D[\cosh(1 - \xi) \sinh \xi + \sinh(1 - \xi) \cosh \xi] &= \sinh \xi \\ -D[\sinh((1 - \xi) + \xi)] &= \sinh \xi \\ -D \sinh 1 &= \sinh \xi \\ D &= -\frac{\sinh \xi}{\sinh 1} \\ \therefore C &= \frac{-\sinh(1 - \xi)}{\sinh 1} \end{aligned}$$

So the solution is,

$$y(x) = \frac{-\sinh(1-x)}{\sinh 1} \int_0^x \sinh \xi f(\xi) d\xi - \frac{\sinh x}{\sinh 1} \int_x^1 \sinh(1-\xi) f(\xi) d\xi \quad (7.22)$$

Suppose we have inhomogeneous boundary conditions. In this case, we want to find a homogeneous solution y_p that solves the inhomogeneous boundary conditions. That is, $\mathcal{L}y_p = 0$ but $y_p(a) \neq 0, y_p(b) \neq 0$ are as required for the inhomogeneous boundary conditions.

Then, by subtracting this solution from the original equation, we can solve using a homogeneous set of boundary conditions. We can find Green's fcn for $\mathcal{L}y_g = f$ with $y_g(a) = y_g(b) = 0$ where $y_g = y - y_p$.

Example 7.2

Suppose $y'' - y = f(x)$ with $y(0) = 0, y(1) = 1$.

$$\begin{aligned} y_p &= A \sinh x + B \cosh x \\ y_p(0) = 0 &\implies B = 0 \\ y_p(1) = 1 &\implies A = \frac{1}{\sinh 1} \end{aligned}$$

Solve for $y_g = y - y_p$ with $y_g(0) = y_g(1) = 0$. Solution $y(x) = \frac{\sinh x}{\sinh 1} + y_g$ (i.e. solution eq. (7.22)).

§7.6 Higher-order ODEs (BVP)

Suppose $\mathcal{L}y = f(x)$ where \mathcal{L} is an n th order linear differential operator, and $\alpha(x)$ is the coefficient for the highest degree derivative ($\alpha(x)\frac{d^n y}{dx^n}$). Suppose that homogeneous boundary conditions are satisfied. Then we can define the Green's function in this case to be the function that solves

$$\mathcal{L}G(x, \xi) = \delta(x - \xi)$$

which has the properties:

1. G_1, G_2 are homogeneous solutions satisfying the homogeneous boundary conditions;
2. $G_1^{(k)}(\xi) = G_2^{(k)}(\xi)$ for $k \in \{0, \dots, n-2\}$;
3. $G_2^{(n-1)}(\xi^+) - G_1^{(n-1)}(\xi^-) = \frac{1}{\alpha(\xi)}$.

See Sheet 3, Q4

§7.7 Eigenfunction expansions of Green's functions

Suppose \mathcal{L} is in Sturm-Liouville form with eigenfunctions $y_n(x)$ and eigenvalues λ_n . We seek $G(x, \xi) = \sum_{n=1}^{\infty} A_n y_n(x)$ satisfying $\mathcal{L}G = \delta(x - \xi)$.

$$\begin{aligned} \mathcal{L}G &= \sum_n A_n \mathcal{L}y_n \\ &= \sum_n A_n \lambda_n w(x) y_n(x) \text{ by eq. (2.12)} \end{aligned}$$

The δ function has expansion

$$\delta(x - \xi) = w(x) \sum_n \frac{y_n(\xi) y_n(x)}{N_n} \text{ by eq. (6.15) where } N_n = \int w y_n^2 dx$$

Hence,

$$A_n(\xi) = \frac{y_n(\xi)}{\lambda_n N_n}$$

Thus,

$$\begin{aligned} G(x, \xi) &= \sum_{n=1}^{\infty} \frac{y_n(\xi) y_n(x)}{\lambda_n \int w y_n^2 dx} \\ &= \sum_{n=1}^{\infty} \frac{Y_n(\xi) Y_N(x)}{\lambda_n} \text{ (unit norm)} \end{aligned} \tag{7.23}$$

which was already obtained earlier in the course when studying Sturm-Liouville theory in eq. (2.31).

§7.8 Constructing Green's function for an initial value problem

Suppose we want to solve

$$\mathcal{L}y = f(t) \text{ for } t \geq a \text{ with } y(a) = y'(a) = 0, \quad (7.24)$$

using $G(t, \tau)$ satisfying $\mathcal{L}G = \delta(t - \tau)$ with the same b.cs.

For $t < \tau$, we have

$$G_1 = Ay_1(t) + By_2(t); \quad Ay_1(a) + By_2(a) = 0; \quad Ay_1'(a) + By_2'(a) = 0$$

If $A \neq B \neq 0$, then we can solve this by dividing out A, B and find $y_1y_2' - y_2y_1' = 0$. Since the Wronskian at a cannot be zero, $A = B = 0$. So $G_1(t, \tau) \equiv 0$ for $a \leq t < \tau$, so there is no change until the 'impulse' at $t = \tau$.

For $t > \tau$, by continuity, eq. (7.12), we must have $G_2(\tau, \tau) = 0$. So we choose a complementary function $G_2 = Dy_+(t)$ with $y_+(t) = Ay_1(t) + By_2(t)$, and b.c $y_+(\tau) = 0$. The discontinuity in the derivative, eq. (7.13), implies that

$$G_2'(\tau, \tau) - \underbrace{G_1'(\tau, \tau)}_0 = Dy_+'(\tau) = \frac{1}{\alpha(\tau)}$$

Hence,

$$Ay_1'(\tau) + By_2'(\tau) = \frac{1}{\alpha(\tau)} \implies D(\tau) = \frac{1}{\alpha(\tau)y_+'(\tau)}$$

or we can find soln for A, B directly.

Hence we have a non-trivial solution

$$G(t, \tau) = \begin{cases} 0 & t < \tau \\ \frac{y_+(t)}{\alpha(\tau)y_+'(\tau)} & t > \tau \end{cases} \quad (7.25)$$

The initial value problem eq. (7.24) has solution

$$y(t) = \int_a^t G_2(t, \tau) f(\tau) d\tau = \int_a^t \frac{y_+(t)f(\tau)}{y_+'(\tau)} d\tau \quad (7.26)$$

Causality is 'built in' to this solution. Only forces which occur before t may have an impact on $y(t)$.

Example 7.3

Let us solve $y'' - y = f(t)$ with $y(0) = y'(0) = 0$. The homogeneous solution and initial conditions are

$$t < \tau \implies G_1 \equiv 0$$

and

$$t > \tau \implies G_2 = Ae^t + Be^{-t}$$

By continuity $G_2(\tau, \tau) = 0 \implies G_2 = D \sinh(t - \tau)$. Now,

$$[G']_{\tau^-}^{\tau^+} = \frac{1}{\alpha(\tau)} = 1 \implies G_2'(\tau, \tau) = D \cosh 0 = D = 1$$

Hence, the solution eq. (7.26) is

$$y(t) = \int_0^t f(\tau) \sinh(t - \tau) d\tau$$

§8 Fourier Transforms

§8.1 Definitions

Definition 8.1 (Fourier transform)

The **Fourier transform** of a function $f(x)$ is

$$\tilde{f}(k) = \mathcal{F}(f)(k) = \int_{-\infty}^{\infty} f(x)e^{-ikx} dx \quad (8.1)$$

The **inverse Fourier transform** is

$$f(x) = \mathcal{F}^{-1}(\tilde{f})(x) = \frac{1}{2\pi} \int_{-\infty}^{\infty} \tilde{f}(k)e^{ikx} dk \quad (8.2)$$

Different internally-consistent definitions exist, which distribute the multiplicative constants in different ways.

Theorem 8.1 (Fourier inversion theorem)

For a function $f(x)$,

$$\mathcal{F}^{-1}(\mathcal{F}(f))(x) = f(x) \quad (8.3)$$

with a sufficient condition that f and \tilde{f} are absolutely integrable, so

$$\int_{-\infty}^{\infty} |f(x)| dx = M < \infty.$$

In particular, $f \rightarrow 0$ as $x \rightarrow \pm\infty$.

Example 8.1

Consider the Gaussian,

$$f(x) = \frac{1}{\sigma\sqrt{\pi}} \exp\left[-\frac{x^2}{\sigma^2}\right] \quad (8.4)$$

We wish to compute its Fourier transform. Since $i \sin kx$ is an odd function,

$$\tilde{f}(k) = \frac{1}{\sigma\sqrt{\pi}} \int_{-\infty}^{\infty} \exp\left[-\frac{x^2}{\sigma^2}\right] \exp[-ikx] dx = \frac{1}{\sigma\sqrt{\pi}} \int_{-\infty}^{\infty} \exp\left[-\frac{x^2}{\sigma^2}\right] \cos(kx) dx$$

Consider, using Leibniz' rule,

$$\frac{d\tilde{f}}{dk} = \frac{-1}{\sigma\sqrt{\pi}} \int_{-\infty}^{\infty} x \exp\left[\frac{-x^2}{\sigma^2}\right] \sin kx \, dx$$

Integrating by parts,

$$\begin{aligned} \frac{d\tilde{f}}{dk} &= \frac{1}{\sigma\sqrt{\pi}} \underbrace{\left[\frac{\sigma^2}{2} \exp\left[\frac{-x^2}{\sigma^2}\right] \sin kx \right]_{-\infty}^{\infty}}_0 - \frac{1}{\sigma\sqrt{\pi}} \int_{-\infty}^{\infty} \frac{k\sigma^2}{2} \exp\left[\frac{-x^2}{\sigma^2}\right] \cos kx \, dx \\ &= -\frac{k\sigma^2}{2} \tilde{f}(k) \end{aligned}$$

This is a differential equation for \tilde{f} , which gives

$$\tilde{f}(k) = C \exp\left[-\frac{k^2\sigma^2}{4}\right]$$

Suppose $k = 0$. Then, in the original expression for the Fourier transform, we can directly find $\tilde{f}(0) = 1$. Hence $C \exp\left[-\frac{0^2\sigma^2}{4}\right] = 1 \implies C = 1$. Hence,

$$\tilde{f}(k) = \exp\left[-\frac{k^2\sigma^2}{4}\right] \quad (8.5)$$

which is another Gaussian with the width parameter inverted.

Exercise 8.2. Show that $\mathcal{F}^{-1}(e^{-k^2\sigma^2/4}) = f(x)$ (try completing the square).

Exercise 8.3. Show that $f(x) = e^{-a|x|}$, $a > 0$, has FT

$$\tilde{f} = \frac{2a}{a^2 + k^2} \quad (8.6)$$

in two ways.

1. Integrate $2 \int_0^{\infty} e^{-ax} \cos kx \, dx$ by parts twice.
2. Integrate $\int_0^{\infty} e^{-(a-ik)x} \, dx + \int_{-\infty}^0 e^{(a+ik)x} \, dx$ directly.

Note that if $f(x) = \begin{cases} e^{-ax} & x > 0 \\ 0 & x \leq 0 \end{cases}$ ($a > 0$) then

$$\tilde{f}(k) = \frac{1}{ik + a} \quad (8.6a)$$

§8.2 Converting Fourier series into Fourier transforms

Recall that the complex form of the Fourier series, eq. (1.13), is

$$f(x) = \sum_{n=-\infty}^{\infty} c_n e^{ik_n x}$$

where $k_n = \frac{n\pi}{L}$. We can write in particular $k_n = n\Delta k$ where $\Delta k = \frac{\pi}{L}$. Then,

$$c_n = \frac{1}{2L} \int_{-L}^L f(x) e^{-ik_n x} dx = \frac{\Delta k}{2\pi} \int_{-L}^L f(x) e^{-ik_n x} dx$$

Now, re-substituting into the Fourier series,

$$f(x) = \sum_{n=-\infty}^{\infty} \frac{\Delta k}{2\pi} e^{ik_n x} \int_{-L}^L f(x') e^{-ik_n x'} dx'$$

But interpreting the sum multiplied by Δk as a Riemann integral,

$$\sum_{n=-\infty}^{\infty} \Delta k g(k_n) \rightarrow \int_{-\infty}^{\infty} g(k) dk \quad (8.6b)$$

So,

$$f(x) \rightarrow \int_{-\infty}^{\infty} \frac{1}{2\pi} e^{ik_n x} \int_{-L}^L f(x') e^{-ik_n x'} dx' dk$$

Taking the limit $L \rightarrow \infty$,

$$f(x) = \frac{1}{2\pi} \int_{-\infty}^{\infty} dk e^{ikx} \int_{-\infty}^{\infty} dx' f(x') e^{-ik_n x'}$$

which is the inverse Fourier transform of the Fourier transform of f , which gives the Fourier inversion theorem. Note that when $f(x)$ is discontinuous at x , the Fourier transform gives

$$\mathcal{F}^{-1}(\mathcal{F}(f))(x) = \frac{1}{2}(f(x_-) + f(x_+)) \quad (8.7)$$

which is analogous to the result for Fourier series.

§8.3 Properties of Fourier series

Recall the definition of the Fourier transform.

$$\tilde{f}(k) = \int_{-\infty}^{\infty} f(x) e^{-ikx} dx$$

Proposition 8.1 (Linearity)

The (inverse) Fourier transform is linear.

$$h(x) = \lambda f(x) + \mu g(x) \iff \tilde{h}(k) = \lambda \tilde{f}(k) + \mu \tilde{g}(k) \quad (8.8)$$

Proposition 8.2 (Translation)

Translated functions transform to multiplicative factors.

$$h(x) = f(x - \lambda) \iff \tilde{h}(k) = e^{-i\lambda k} \tilde{f}(k) \quad (8.9)$$

Proof. This is because

$$\tilde{h}(k) = \int f(x - \lambda) e^{-ikx} dx = \int f(y) e^{-ik(y+\lambda)} dy = e^{-i\lambda k} \tilde{f}(k)$$

□

Proposition 8.3 (Frequency Shift)

Frequency shifts transform to translations in frequency space.

$$h(x) = e^{i\lambda x} f(x) \implies \tilde{h}(k) = \tilde{f}(k - \lambda) \quad (8.10)$$

Proposition 8.4 (Scaling)

A scalar multiple applied to the argument transforms into an inverse scalar multiple.

$$h(x) = f(\lambda x) \iff \tilde{h}(k) = \frac{1}{|\lambda|} \tilde{f}\left(\frac{k}{\lambda}\right) \quad (8.11)$$

Proposition 8.5 (Multiplication by x)

Multiplication by x transforms into an imaginary derivative.

$$h(x) = x f(x) \iff \tilde{h}(k) = i \tilde{f}'(k) \quad (8.12)$$

Proof. This is because

$$\int_{-\infty}^{\infty} x f(x) e^{-ikx} dx = \frac{-1}{i} \frac{d}{dk} \int_{-\infty}^{\infty} f(x) e^{-ikx} dx$$

□

Proposition 8.6 (Derivatives)Derivatives transform into a multiplication by ik .

$$h(x) = f'(x) \iff \tilde{h}(k) = ik\tilde{f}(k) \quad (8.13)$$

Proof. This is because we can integrate by parts and find

$$\tilde{h}(k) = \int_{-\infty}^{\infty} f'(x)e^{-ikx} dx = \underbrace{\left[f(x)e^{-ikx} \right]_{-\infty}^{\infty}}_{=0} + ik \int_{-\infty}^{\infty} f(x)e^{-ikx} dx$$

□

Proposition 8.7 (General duality)

$$g(x) = \tilde{f}(x) \iff \tilde{g}(k) = 2\pi f(-k) \quad (8.14)$$

Proof. Consider eq. (8.2) with mapping $x \mapsto -x$, we get

$$f(-x) = \frac{1}{2\pi} \int_{-\infty}^{\infty} \tilde{f}(k)e^{-ikx} dk.$$

Now swap k and x , treating \tilde{f} now as a function in position space

$$f(-k) = \frac{1}{2\pi} \int_{-\infty}^{\infty} \tilde{f}(x)e^{-ikx} dx.$$

Thus

$$g(x) = \tilde{f}(x) \iff \tilde{g}(k) = 2\pi f(-k)$$

□

Corollary 8.1

$$f(-x) = \frac{1}{2\pi} \mathcal{F}(\mathcal{F}(f))(x)$$

Finally,

$$\mathcal{F}^4(f)(x) = 4\pi^2 f(x)$$

Exercise 8.4. Verify these properties.

Example 8.2

Consider a function defined by

$$f(x) = \begin{cases} 1 & |x| \leq a \\ 0 & \text{otherwise} \end{cases}$$

for some $a > 0$. By the definition of the Fourier transform,

$$\tilde{f}(k) = \int_{-\infty}^{\infty} f(x)e^{-ikx} dx = \int_{-a}^a e^{-ikx} dx = \int_{-a}^a \cos kx dx = \frac{2}{k} \sin ka \quad (8.15)$$

By the Fourier inversion theorem,

$$\frac{1}{\pi} \int_{-\infty}^{\infty} e^{ikx} \frac{1}{k} \sin ka dk = f(x)$$

for $x \neq a$.

Now, in this expression, let $x = 0$ and let $k \mapsto x$. We arrive at the Dirichlet discontinuous formula.

$$\int_0^{\infty} \frac{\sin ax}{x} dx = \frac{\pi}{2} \operatorname{sgn} a = \begin{cases} \frac{\pi}{2} & a > 0 \\ 0 & a = 0 \\ -\frac{\pi}{2} & a < 0 \end{cases} \quad (8.16)$$

Here, we allow $a < 0$, so $\sin(-ax) = -\sin ax$.

§8.4 Convolution theorem

We want to multiply Fourier transforms in the frequency domain (transformed space). This is useful for filtering or processing signals.

$$\tilde{h}(k) = \tilde{f}(k)\tilde{g}(k)$$

Consider the inverse.

$$\begin{aligned} h(x) &= \frac{1}{2\pi} \int_{-\infty}^{\infty} \tilde{f}(k)\tilde{g}(k)e^{ikx} dk \\ &= \frac{1}{2\pi} \int_{-\infty}^{\infty} \left(\int_{-\infty}^{\infty} f(y)e^{-iky} dy \right) \tilde{g}(k)e^{ikx} dk \\ &= \int_{-\infty}^{\infty} f(y) \left(\frac{1}{2\pi} \int_{-\infty}^{\infty} e^{-iky}\tilde{g}(k)e^{ikx} dk \right) dy \\ &= \int_{-\infty}^{\infty} f(y) \left(\frac{1}{2\pi} \int_{-\infty}^{\infty} \tilde{g}(k)e^{ik(x-y)} dk \right) dy \end{aligned}$$

$$\begin{aligned}
&= \int_{-\infty}^{\infty} f(y)g(x-y) dy \text{ by eq. (8.9)} \\
&\equiv (f * g)(x)
\end{aligned} \tag{8.17}$$

where $f * g$ is called the *convolution* of f and g . By duality eq. (8.14), we also have

$$h(x) = f(x)g(x) \iff \tilde{h}(k) = \frac{1}{2\pi} \int_{-\infty}^{\infty} \tilde{f}(p)\tilde{g}(k-p) dp = \frac{1}{2\pi} (\tilde{f} * \tilde{g})(k) \tag{8.18}$$

§8.5 Parseval's theorem

Consider $h(x) = g^*(-x)$.

$$\begin{aligned}
\tilde{h}(k) &= \int_{-\infty}^{\infty} g^*(-x)e^{-ikx} dx \\
&= \left[\int_{-\infty}^{\infty} g(-x)e^{ikx} dx \right]^*
\end{aligned}$$

Let $-x \mapsto y$

$$\begin{aligned}
&= \left[\int_{-\infty}^{\infty} g(y)e^{-iky} dy \right]^* \\
&= \tilde{g}^*(k)
\end{aligned}$$

Substituting this into the convolution theorem eq. (8.17), with $g(x) \mapsto g^*(-x)$, we have (RHS is the inverse Fourier transform)

$$\int_{-\infty}^{\infty} f(y)g^*(y-x) dy = \frac{1}{2\pi} \int_{-\infty}^{\infty} \tilde{f}(k)\tilde{g}^*(k)e^{ikx} dx$$

Taking $x = 0$ in this expression and mapping $y \mapsto x$, we find

$$\int_{-\infty}^{\infty} f(x)g^*(x) dx = \frac{1}{2\pi} \int_{-\infty}^{\infty} \tilde{f}(k)\tilde{g}^*(k) dk \tag{8.19}$$

Equivalently,

$$\langle g, f \rangle = \frac{1}{2\pi} \langle \tilde{g}, \tilde{f} \rangle \tag{8.20}$$

So the inner product is conserved under the Fourier transform (up to a factor of 2π). Now, by setting $g^* = f^*$, we have

$$\int_{-\infty}^{\infty} |f(x)|^2 dx = \frac{1}{2\pi} \int_{-\infty}^{\infty} |\tilde{f}(k)|^2 dk$$

This is Parseval's theorem.

§8.6 Fourier transforms of generalised functions

We can apply Fourier transforms to generalised functions by considering limiting distributions. Consider the inversion

$$\begin{aligned} f(x) &= \mathcal{F}^{-1}(\mathcal{F}(f))(x) \\ &= \frac{1}{2\pi} \int_{-\infty}^{\infty} \left[\int_{-\infty}^{\infty} f(u) e^{-iku} \, du \right] e^{ikx} \, dk \\ &= \int_{-\infty}^{\infty} f(u) \underbrace{\left[\frac{1}{2\pi} \int_{-\infty}^{\infty} e^{-ik(x-u)} \, dk \right]}_{\delta(x-u)} \, du \end{aligned}$$

In order to reconstruct $f(x)$ on the right hand side for any function f , we must have that the bracketed term is $\delta(x - u)$. So we identify

$$\delta(x - u) = \frac{1}{2\pi} \int_{-\infty}^{\infty} e^{ik(x-u)} \, dk$$

- If $f(x) = \delta(x)$,

$$\tilde{f}(k) = \int_{-\infty}^{\infty} \delta(x) e^{ikx} \, dx = 1 \quad (8.21)$$

This can be thought of as the Fourier transform of an infinitely thin Gaussian, which becomes an infinitely wide Gaussian (a constant).

- If $f(x) = 1$, then

$$\tilde{f}(k) = \int_{-\infty}^{\infty} e^{-ikx} \, dx = 2\pi\delta(k) \quad (8.22)$$

This can also be found by the duality formula eq. (8.14).

- If $f(x) = \delta(x - a)$, using eq. (8.9) we have

$$\tilde{f}(k) = e^{-ika} \quad (8.23)$$

This is a translation of the original Fourier transform for the δ function above.

§8.7 Trigonometric functions

Let $f(x) = \cos \omega x = \frac{1}{2}(e^{i\omega x} + e^{-i\omega x})$. Then,

$$\tilde{f}(k) = \pi(\delta(k + \omega) + \delta(k - \omega)) \quad (8.24)$$

For $f(x) = \sin \omega x$, we have

$$\tilde{f}(k) = i\pi(\delta(k + \omega) - \delta(k - \omega))$$

Using duality eq. (8.14),

$$\begin{aligned} f(x) &= \frac{1}{2}(\delta(x+a) + \delta(x-a)) \implies \tilde{f}(k) = \cos ka \\ f(x) &= \frac{1}{2i}(\delta(x+a) - \delta(x-a)) \implies \tilde{f}(k) = \sin ka \end{aligned}$$

§8.8 Heaviside functions

Let $H(x)$ be the Heaviside function, such that $H(0) = \frac{1}{2}$. Then, $H(x) + H(-x) = 1$ for all x and is cts at $x = 0$. We can take the Fourier transform of this and find by eq. (8.22)

$$\tilde{H}(k) + \tilde{H}(-k) = 2\pi\delta(k) \quad (*)$$

Recall that $H'(x) = \delta(x)$, eq. (6.7). Thus by eqs. (8.13) and (8.21),

$$ik\tilde{H}(x) = \tilde{\delta}(k) = 1 \quad (\dagger)$$

Since $k\delta(k) = 0$, the two equations for \tilde{H} can be consistent if we take

$$\tilde{H}(k) = \pi\delta(k) + \frac{1}{ik} \quad (8.25)$$

§8.9 Dirichlet discontinuous formula

Recall the Dirichlet discontinuous formula eq. (8.16):

$$\int_0^\infty \frac{\sin ax}{x} dx = \frac{\pi}{2} \operatorname{sgn} a = \begin{cases} \frac{\pi}{2} & a > 0 \\ 0 & a = 0 \\ -\frac{\pi}{2} & a < 0 \end{cases}$$

We can rewrite this as

$$\frac{1}{2} \operatorname{sgn} x = \frac{1}{2\pi} \int_{-\infty}^{\infty} \frac{e^{ikx}}{ik} dk$$

since the cosine term divided by ik is odd. Hence,

$$f(x) = \frac{1}{2} \operatorname{sgn} x \iff \tilde{f}(k) = \frac{1}{ik} \quad (8.26)$$

This is the preferred form for a Heaviside-type function when used in Fourier transforms.

§8.10 Solving ODEs for boundary value problems

Consider $y'' - y = f(x)$ with homogeneous boundary conditions $y \rightarrow 0$ as $x \rightarrow \pm\infty$. Taking the Fourier transform of this expression, we find by eq. (8.13)

$$(-k^2 - 1)\tilde{y} = \tilde{f}$$

Thus, the solution is

$$\tilde{y}(k) = \frac{-\tilde{f}(k)}{1 + k^2} \equiv \tilde{f}(k)\tilde{g}(k)$$

where $\tilde{g}(k) = \frac{-1}{1+k^2}$. Note that $\tilde{g}(k)$ is the Fourier transform of $g(x) = -\frac{1}{2}e^{-|x|}$, eq. (8.6). Applying the convolution theorem eq. (8.17),

$$\begin{aligned} y(x) &= \int_{-\infty}^{\infty} f(u)g(x-u) du \\ &= -\frac{1}{2} \int_{-\infty}^{\infty} f(u)e^{-|x-u|} du \\ &= -\frac{1}{2} \left[\int_{-\infty}^x f(u)e^{u-x} du + \int_x^{\infty} f(u)e^{x-u} du \right] \end{aligned}$$

This is in the form of a boundary value problem Green's function eq. (7.20). We can construct the same results by constructing the Green's function directly or by using inverse Fourier transform on $\tilde{y}(k)$.

§8.11 Signal processing

Suppose we have an input signal $\mathcal{I}(t)$, which is acted on by some linear operator \mathcal{L}_{in} to yield an output $\mathcal{O}(t)$. The Fourier transform of the input $\tilde{\mathcal{I}}(\omega)$ is called the **resolution**.

$$\tilde{\mathcal{I}}(\omega) = \int_{-\infty}^{\infty} \mathcal{I}(t)e^{-i\omega t} dt \quad (8.27)$$

In the frequency domain, the action of \mathcal{L}_{in} on $\mathcal{I}(t)$ means that $\tilde{\mathcal{I}}(\omega)$ is multiplied by a **transfer function** $\tilde{\mathcal{R}}(\omega)$ to yield output,

$$\mathcal{O}(t) = \frac{1}{2\pi} \int_{-\infty}^{\infty} \tilde{\mathcal{R}}(\omega)\tilde{\mathcal{I}}(\omega)e^{i\omega t} d\omega \quad (8.28)$$

The inverse Fourier transform of the transfer function, \mathcal{R} , is called the **response function**, which is given by

$$\mathcal{R}(t) = \frac{1}{2\pi} \int_{-\infty}^{\infty} \tilde{\mathcal{R}}(\omega)e^{i\omega t} d\omega \quad (8.29)$$

By the convolution theorem,

$$\mathcal{O}(t) = \int_{-\infty}^{\infty} \mathcal{I}(u)\mathcal{R}(t-u) du$$

Suppose there is no input ($\mathcal{I}(t) = 0$) for $t < 0$. By causality, there should be zero output for the response function ($\mathcal{R}(t) = 0$) for $t < 0$. Therefore, we require $0 < u < t$ and hence

$$\mathcal{O}(t) = \int_0^t \mathcal{I}(u)\mathcal{R}(t-u) du \quad (8.30)$$

which resembles an initial value problem Green's function eq. (7.26).

§8.12 General transfer functions for ODEs

Suppose an input-output relationship is given by a linear ODE (nth order).

$$\mathcal{L}\mathcal{O}(t) \equiv \left(\sum_{i=0}^n a_i \frac{d^i}{dx^i} \right) \mathcal{O}(t) \equiv \mathcal{I}(t) \quad (8.31)$$

Here, $\mathcal{L}_{in} = 1$. We want to solve this ODE using a Fourier transform.

$$(a_0 + a_1 i\omega - a_2 \omega^2 - a_3 i\omega^3 + \dots + a_n (i\omega)^n) \tilde{\mathcal{O}}(\omega) = \tilde{\mathcal{I}}(\omega)$$

We can solve this algebraically in Fourier transform space. The transfer function is

$$\tilde{\mathcal{R}}(\omega) = \frac{1}{a_0 + \dots + a_n (i\omega)^n} \quad (8.32)$$

We factorise the denominator to find partial fractions. Suppose there are J distinct roots $(i\omega - c_j)^{k_j}$, where k_j is the algebraic multiplicity of the j th root, so $\sum_{j=1}^J k_j = n$. So we can write

$$\tilde{\mathcal{R}}(\omega) = \frac{1}{(i\omega - c_1)^{k_1} \dots (i\omega - c_J)^{k_J}}$$

Expressing this as partial fractions,

$$\tilde{\mathcal{R}}(\omega) = \sum_{j=1}^J \sum_{m=1}^{k_j} \frac{\Gamma_{jm}}{(i\omega - c_j)^m} \quad (8.33)$$

The Γ_{jm} terms are constant. To solve this, we must find the inverse Fourier transform of $(i\omega - a)^{-m}$. Recall that eq. (8.6a)

$$\mathcal{F}^{-1} \left(\frac{1}{i\omega - a} \right) = \begin{cases} e^{at} & t > 0 \\ 0 & t < 0 \end{cases}$$

for $\text{Re } a < 0$. So we will require $\text{Re } c_j < 0$ for all j to eliminate exponentially growing solutions. Note that for $m = 2$,

$$i \frac{d}{d\omega} \left(\frac{1}{i\omega - a} \right) = \frac{1}{(i\omega - a)^2}$$

and recall eq. (8.12)

$$\mathcal{F}(tf(t)) = i\mathcal{F}'(\omega)$$

Hence,

$$\mathcal{F}^{-1} \left(\frac{1}{(i\omega - a)^2} \right) = \begin{cases} te^{at} & t > 0 \\ 0 & t < 0 \end{cases}$$

Inductively, we arrive at

$$\mathcal{F}^{-1} \left(\frac{1}{(i\omega - a)^m} \right) = \begin{cases} \frac{t^{m-1}}{(m-1)!} e^{at} & t > 0 \\ 0 & t < 0 \end{cases} \quad (8.34)$$

We can therefore invert any transfer function to obtain the response function. Thus the response function takes the form

$$\mathcal{R}(t) = \sum_{j=1}^J \sum_{m=1}^{k_j} \Gamma_{jm} \frac{t^{m-1}}{(m-1)!} e^{c_j t}, \quad t > 0 \quad (8.35)$$

and zero for $t < 0$. We can now solve such differential equations, eq. (8.31), in Green's function form eq. (8.30), or directly invert $\tilde{\mathcal{R}}(\omega)\tilde{\mathcal{L}}(\omega)$ for a polynomial $\tilde{\mathcal{L}}(\omega)$.

§8.13 Damped oscillator

We can use the Fourier transform method to solve the differential equation

$$\mathcal{L}y \equiv y'' + 2py' + (p^2 + q^2)y = f(t)$$

where $p > 0$. Consider homogeneous boundary conditions $y(0) = y'(0) = 0$. The Fourier transform is

$$(i\omega)^2 \tilde{y} + 2ip\omega \tilde{y} + (p^2 + q^2)\tilde{y} = \tilde{f}$$

Hence,

$$\tilde{y} = \frac{\tilde{f}}{-\omega^2 + 2ip\omega + p^2 + q^2} \equiv \tilde{R}\tilde{f}$$

We can invert this using the convolution theorem by inverting \tilde{R} .

$$y(t) = \int_0^t \mathcal{R}(t - \tau) f(\tau) d\tau$$

where the response function is

$$\mathcal{R}(t - \tau) = \frac{1}{2\pi} \int_{-\infty}^{\infty} \frac{e^{i\omega(t-\tau)}}{p^2 + q^2 + 2ip\omega - \omega^2} d\omega$$

We can show that $\mathcal{L}\mathcal{R}(t - \tau) = \delta(t - \tau)$ using eq. (8.23); in other words, \mathcal{R} is the Green's function (Sheet 3, Q4).

§8.14 Discrete sampling and the Nyquist frequency

Suppose a signal $h(t)$ is sampled at equal times $t_n = n\Delta$ with a time step Δ and values

$$h_n = h(t_n) = h(n\Delta), \quad n \in \mathbb{Z} \quad (8.36)$$

The sampling frequency is therefore Δ^{-1} , so the sampling angular velocity is $\omega_s = 2\pi f_s = \frac{2\pi}{\Delta}$.

Definition 8.2 (Nyquist Frequency)

The **Nyquist frequency** is the highest frequency actually sampled at Δ ,

$$f_c = \frac{1}{2\Delta} \quad (8.37)$$

Suppose we have a signal g_f with a given frequency f . We will write

$$g_f(t) = A \cos(2\pi ft + \varphi) = \operatorname{Re} \left(A e^{2\pi i f t + \varphi} \right) = \frac{1}{2} \left(A e^{2\pi i f t + \varphi} \right) + \frac{1}{2} \left(A e^{-2\pi i f t + \varphi} \right) \quad (8.38)$$

where $A \in \mathbb{R}$. Note that this signal has two 'frequencies'; a positive and a negative frequency. The combination of these frequencies gives the full wave.

Suppose we sample $g_f(t)$ at the Nyquist frequency, so $f = f_c$. Then,

$$\begin{aligned} g_{f_c}(t_n) &= A \cos \left(2\pi \frac{1}{2\Delta} n\Delta + \varphi \right) \\ &= A \cos(\pi n + \varphi) \\ &= A \cos \pi n \cos \varphi + A \sin \pi n \sin \varphi \\ &= A' \cos(2\pi f_c t_n) \end{aligned} \quad (8.39)$$

where $A' = A \cos \varphi$. This has removed half of the information about the wave; the amplitude and the phase have become degenerate. We have lost phase/amplitude information, there is no longer any distinction between them. We can identify f_c with $-f_c$

when considering the remaining information; we say that the two frequencies are *aliased* together.

Now, suppose we sample at greater than the Nyquist frequency, in particular $f = f_c + \delta f > f_c$, where for simplicity we let $\delta f < f_c$. As an exercise, show that

$$\begin{aligned} g_f(t_n) &= A \cos(2\pi(f_c + \delta f)t_n + \varphi) \\ &= A \cos(2\pi(f_c - \delta f)t_n - \varphi) \end{aligned} \quad (8.40)$$

So frequencies above the Nyquist frequency are reinterpreted after the sampling as a frequency lower than the Nyquist frequency. This aliases $f_c + \delta f$ with $f_c - \delta f$.

§8.15 Nyquist-Shannon sampling theorem

Definition 8.3 (Bandwidth-Limited)

A signal $g(t)$ is **bandwidth-limited** if it contains no frequencies above $\omega_{\max} = 2\pi f_{\max}$. In other words, $\tilde{g}(\omega) = 0$ for all $|\omega| > \omega_{\max}$. In this case,

$$g(t) = \frac{1}{2\pi} \int_{-\infty}^{\infty} \tilde{g}(\omega) e^{i\omega t} d\omega = \frac{1}{2\pi} \int_{-\omega_{\max}}^{\omega_{\max}} \tilde{g}(\omega) e^{i\omega t} d\omega \quad (8.41)$$

Suppose we set the sampling rate to the Nyquist frequency, so $\Delta = \frac{1}{2f_{\max}}$. Then,

$$g_n \equiv g(t_n) = \frac{1}{2\pi} \int_{-\omega_{\max}}^{\omega_{\max}} \tilde{g}(\omega) e^{i\pi n\omega/\omega_{\max}} d\omega$$

This is a complex Fourier series coefficient eq. (1.13) c_n , multiplied by $\frac{\omega_{\max}}{\pi}$. The Fourier series is periodic in ω with period $2\omega_{\max}$, not in space or time.

$$\tilde{g}_{\text{per}}(\omega) = \frac{\pi}{\omega_{\max}} \sum_{n=-\infty}^{\infty} g_n e^{-i\pi n\omega/\omega_{\max}} \quad (8.42)$$

The actual Fourier transform \tilde{g} is found by multiplying by a top hat window function

$$\tilde{h}(\omega) = \begin{cases} 1 & |\omega| \leq \omega_{\max} \\ 0 & \text{otherwise} \end{cases}$$

Hence,

$$\tilde{g}(\omega) = \tilde{g}_{\text{per}}(\omega) \tilde{h}(\omega) \quad (8.43)$$

Note that this relation is exact. Inverting this expression,

$$g(t) = \frac{1}{2\pi} \int_{-\infty}^{\infty} \tilde{g}_{\text{per}}(\omega) \tilde{h}(\omega) e^{i\omega t} d\omega$$

$$= \frac{1}{2\omega_{\max}} \sum_{n=-\infty}^{\infty} g_n \int_{-\omega_{\max}}^{\omega_{\max}} \exp\left(i\omega\left(t - \frac{n\pi}{\omega_{\max}}\right)\right) d\omega$$

Only the cosine term is even, hence

$$g(t) = \frac{1}{2\omega_{\max}} \sum_{n=-\infty}^{\infty} g_n \frac{\sin(\omega_{\max}t - \pi n)}{\omega_{\max}t - \pi n} \quad (8.44)$$

Hence, $g(t)$ can be written *exactly* as a combination of countably many discrete sample points.

§8.16 Discrete Fourier transform

Suppose we have a finite number of samples

$$h_m = h(t_m) \text{ for } t_m = m\Delta, \text{ where } m = 0, \dots, N-1 \quad (8.45)$$

We will approximate the Fourier transform for N frequencies within the Nyquist frequency $f_c = \frac{1}{2\Delta}$, using equally-spaced frequencies, given by $\Delta_f = \frac{1}{N\Delta}$ in the range $-f_c \leq f \leq f_c$. We could take the convention $f_n = n\Delta_f = \frac{n}{N\Delta}$ for $n = -\frac{N}{2}, \dots, \frac{N}{2}$. However, this overcounts the Nyquist frequency (which is aliased, eq. (8.39)), giving $N+1$ frequencies instead of the desired N . Since frequencies above the Nyquist frequency are aliased to below it, eq. (8.40):

$$\left(\frac{N}{2} + m\right)\Delta_f = f_c + \delta f \mapsto \left(\frac{N}{2} - m\right)\Delta_f = -(f_c - \delta f)$$

we can instead use the convention $f_n = n\Delta_f = \frac{n}{N\Delta}$ for

$$n = 0, \dots, N-1 \quad (8.46)$$

This counts the Nyquist frequency only once.

The **discrete FT** at a frequency f_n becomes

$$\begin{aligned} \tilde{h}(f_n) &= \int_{-\infty}^{\infty} h(t) e^{-2\pi i f_n t} dt \\ &\approx \Delta \sum_{m=0}^{N-1} h_m e^{-2\pi i f_n t_m} \\ &= \Delta \sum_{m=0}^{N-1} h_m e^{-2\pi i m n / N} \\ &= \Delta \tilde{h}_d(f_n) \end{aligned} \quad (8.47)$$

where the function $\tilde{h}_d(f_n)$ is the discrete Fourier transform.

The matrix

$$[\text{DFT}]_{mn} = e^{-2\pi imn/N}, \quad m, n = 0, 1, \dots, N-1 \quad (8.48)$$

defines the discrete Fourier transform for the vector $h = \{h_m\}$. The discrete Fourier transform is then

$$\tilde{h}_d = [\text{DFT}]h$$

By inverting the discrete Fourier transform matrix, we find

$$h = [\text{DFT}]^{-1}\tilde{h}_d = \frac{1}{N}[\text{DFT}]^\dagger\tilde{h}_d$$

since the inverse of the discrete Fourier transform matrix is its adjoint. The matrix is built from roots of unity $\omega = e^{-2\pi i/N}$. So, for instance, $n = 4$ gives $\omega = e^{-2\pi i/4} = -i$ giving

$$[\text{DFT}] = \begin{pmatrix} 1 & 1 & 1 & 1 \\ 1 & -i & -1 & i \\ 1 & -1 & 1 & -1 \\ 1 & i & -1 & -i \end{pmatrix}$$

The inverse discrete Fourier transform is

$$\begin{aligned} h_m &= h(t_m) \\ &= \frac{1}{2\pi} \int_{-\infty}^{\infty} \tilde{h}(\omega) e^{i\omega t_m} d\omega \\ &= \int_{-\infty}^{\infty} \tilde{h}(f) e^{2\pi i f t_m} df \\ &\approx \frac{1}{\Delta N} \sum_{n=0}^{N-1} \Delta \tilde{h}_d(f_n) e^{2\pi imn/N} \\ &= \frac{1}{N} \sum_{n=0}^{N-1} \tilde{h}_n e^{2\pi imn/N} \end{aligned}$$

Hence, we can interpolate the initial function from its samples.

$$h(t) = \frac{1}{N} \sum_{n=0}^{N-1} \tilde{h}_n e^{2\pi int/N}$$

Parseval's theorem becomes,

$$\sum_{m=0}^{N-1} |h_m|^2 = \frac{1}{N} \sum_{n=0}^{N-1} |\tilde{h}_n|^2 \quad (8.49)$$

Exercise 8.5. Prove this.

The convolution theorem for g_m, h_m is

$$c_k = \sum_{m=0}^{N-1} g_m h_{k-m} \iff \tilde{c}_k = \tilde{g}_k \tilde{h}_k \quad (8.50)$$

§8.17 Fast Fourier transform (non-examinable)

While the discrete Fourier transform is an order $O(N^2)$ operation, we can reduce this into an order $O(n \log N)$ operation. Such a simplification is called the **fast Fourier transform**. We can split the discrete Fourier transform into even and odd parts, noting that $\omega_N = e^{-2\pi i/N}$ implies $\omega_N^2 = e^{-2\pi i/(N/2)} = \omega_{N/2}$

$$\begin{aligned} \tilde{h}_k &= \sum_{n=0}^{N-1} h_n \omega_N^{nk} \\ &= \sum_{m=0}^{N/2-1} h_{2m} \omega_N^{2mk} + \sum_{m=0}^{N/2-1} h_{2m+1} \omega_N^{(2m+1)k} \\ &= \sum_{m=0}^{N/2-1} h_{2m} (\omega_N^2)^{mk} + \omega_N^k \sum_{m=0}^{N/2-1} h_{2m+1} (\omega_N^2)^{mk} \\ &= \sum_{m=0}^{N/2-1} h_{2m} (\omega_{N/2})^{mk} + \omega_N^k \sum_{m=0}^{N/2-1} h_{2m+1} (\omega_{N/2})^{mk} \end{aligned}$$

This algorithm iteratively reduces the Fourier transform's complexity by a factor of two, until the trivial case of finding the discrete Fourier transform of two data points.

Part IV

PDEs on Unbounded Domains

§9 Method of characteristics

§9.1 Well-posed Cauchy problems

Solving partial differential equations depends on the nature of the equations in combination with the boundary or initial data. A **Cauchy problem** is the partial differential equation for some function φ together with the auxiliary data (in φ and its derivatives) specified on a surface (or a curve in two dimensions), which is called **Cauchy data**. For a Cauchy problem to be *well-posed*, we require that

1. a solution exists (we do not have excessive auxiliary data);
2. the solution is unique (we do not have insufficient auxiliary data); and
3. the solution depends continuously on the auxiliary data.

§9.2 Method of characteristics

Consider a parametrised curve C given by Cartesian coordinates $(x(s), y(s))$. The tangent vector is

$$v = \left(\frac{dx(s)}{ds}, \frac{dy(s)}{ds} \right)$$

We then define the directional derivative of a function $\varphi(x, y)$ by

$$\left. \frac{d\varphi}{ds} \right|_C = \frac{dx(s)}{ds} \frac{\partial \varphi}{\partial x} + \frac{dy(s)}{ds} \frac{\partial \varphi}{\partial y} = v \cdot \nabla \varphi \Big|_C \quad (9.1)$$

Suppose $v \cdot \nabla \varphi = 0$ then $\frac{d\varphi}{ds} = 0$ and hence φ is constant along the curve. Suppose there exists a vector field

$$u = (\alpha(x, y), \beta(x, y)) \quad (9.2)$$

with a family of non-intersecting integral curves C which fill the plane (or domain of the function more generally), such that at a point (x, y) the integral curve has tangent vector $u(x, y)$.

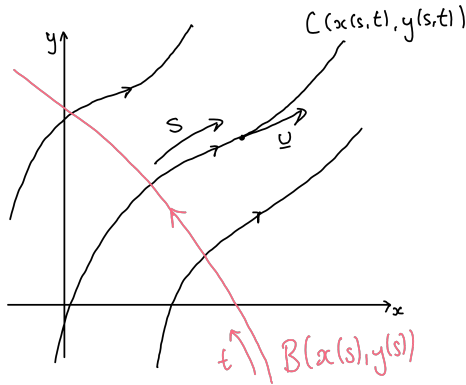

Now, define a curve B by $(x(t), y(t))$ such that B is transverse to u ; its tangent is nowhere parallel to u .

$$w = \left(\frac{dx(t)}{dt}, \frac{dy(t)}{dt} \right) \nparallel (\alpha(x, y), \beta(x, y)) = u$$

This can be used to parametrise the family of curves by labelling each curve C with the value of t at the intersection point between it and B . Along the curve, we use s such that $s = 0$ at the intersection. The integral curves $(x(s, t), y(s, t))$ satisfy

$$\frac{dx}{ds} = \alpha(x, y); \quad \frac{dy}{ds} = \beta(x, y) \tag{9.3}$$

We can solve these equations to find a family of characteristic curves, along which t remains constant. This yields a new coordinate system (s, t) associated with a differential equation we wish to solve.

§9.3 Characteristics of a first order PDE

Consider

$$\alpha(x, y) \frac{\partial \varphi}{\partial x} + \beta(x, y) \frac{\partial \varphi}{\partial y} = 0 \tag{9.4}$$

with Cauchy data on an initial curve B , defined by $(x(t), y(t))$:

$$\varphi(x(t), y(t)) = f(t) \tag{9.5}$$

Note,

$$\alpha \varphi_x + \beta \varphi_y = u \cdot \nabla \varphi = \left. \frac{d\varphi}{ds} \right|_C$$

This is exactly the directional derivative along the integral curve C , defined by $u = (\alpha, \beta)$, which are called the **characteristic curves of the PDE**. Since $\frac{d\varphi}{ds} = \alpha \varphi_x + \beta \varphi_y = 0$ from

the original PDE eq. (9.4), the function $\varphi(x, y)$ is constant along this curve C . In other words, the Cauchy data $f(t)$ defined on B at $s = 0$ is propagated constantly along the integral curves. This gives the solution

$$\varphi(s, t) = \varphi(x(s, t), y(s, t)) = f(t) \quad (9.6)$$

To obtain φ in the original coordinates, we need to transform from s, t -space into x, y -space. Provided that the Jacobian $J = x_t y_s - x_s y_t$ is nonzero, we can invert the transformation and find s, t as functions of x, y . This gives

$$\varphi(x, y) = f(t(x, y)) \quad (9.7)$$

To solve such a PDE i.e. eq. (9.4) given eq. (9.5), we will typically use the following steps.

1. Find the characteristic equations eq. (9.3), $\frac{dx}{ds} = \alpha, \frac{dy}{ds} = \beta$.
2. Parametrise the initial conditions on

$$B(x(t), y(t)) \quad (9.8)$$

3. Solve the characteristic equations to find $x = x(s, t)$ and $y = y(s, t)$ subject to the initial conditions, eq. (9.8), at $s = 0$.
4. Solve the equation for φ , eq. (9.4) with eq. (9.1), given by $\frac{d\varphi}{ds} = \alpha\varphi_x + \beta\varphi_y = 0$, so φ is constant along the integral curves, giving $\varphi(s, t) = f(t)$, eq. (9.6).
5. Invert the relations $s = s(x, y)$ and $t = t(x, y)$, then find φ in terms of x, y .

Example 9.1

Consider the equation

$$\frac{d\varphi(x, y)}{dx} = 0$$

such that

$$\varphi(0, y) = h(y)$$

1. The characteristic equations are given by

$$\frac{dx}{ds} = \alpha = 1; \quad \frac{dy}{ds} = \beta = 0 \quad (*)$$

2. The initial curve B is given by

$$(x(t), y(t)) = (0, t) \quad (\dagger)$$

3. Solving the characteristic equations (*),

$$x = s + c(t); \quad y = d(t)$$

At $x = 0$, we must have $s = 0$, so $c = 0$. Further, $y = t$ hence $d = t$. Thus,

$$x = s; \quad y = t$$

4. Thus,

$$\frac{d\varphi}{dx} = 0 \implies \varphi(s, t) = h(t) \implies \varphi(x, y) = h(y)$$

Example 9.2

Consider

$$e^x \varphi_x + \varphi_y = 0; \quad \varphi(x, 0) = \cosh x$$

1. The characteristic equations are

$$\frac{dx}{ds} = e^x; \quad \frac{dy}{ds} = 1 \quad (*)$$

2. The initial conditions are

$$x(t) = t; \quad y(t) = 0 \quad (\dagger)$$

We solve the characteristic equation subject to these initial conditions, giving

$$-e^{-x} = s + c(t); \quad y = s + d(t)$$

$s = 0$ ($x = t$) implies $-e^{-t} = c(t)$ and $y = 0 = d(t)$. Hence

$$e^{-x} = e^{-t} - s; \quad y = s$$

3. Now,

$$\frac{d\varphi}{ds} = 0 \implies \varphi(s, t) = \cosh t$$

4. Since $s = y, e^{-t} = y + e^{-x}$, we have $t = -\log(y + e^{-x})$. Thus,

$$\varphi(x, y) = \cosh [-\log(y + e^{-x})]$$

§9.4 Inhomogeneous first order PDEs

Suppose we now wish to solve

$$\alpha(x, y)\varphi_x + \beta(x, y)\varphi_y = \gamma(x, y) \quad (9.9)$$

with Cauchy data $\varphi(x(t), y(t)) = f(t)$ along a curve B . The characteristic curves are the same as the homogeneous case eq. (9.4). However, the directional derivative no longer vanishes:

$$\left. \frac{d\varphi}{ds} \right|_C = u \cdot \nabla \varphi = \gamma(x, y) \quad (9.10)$$

where $\varphi = f(t)$ at $s = 0$ on B . So $f(t)$ is no longer propagated constantly across characteristic polynomials, but is instead propagated according to the ODE in s eq. (9.10). We must therefore solve this ODE along C before reverting to x, y coordinates.

Example 9.3

Consider

$$\varphi_x + 2\varphi_y = ye^x; \quad \varphi(x, x) = \sin x$$

1. The characteristic equation is given by

$$\frac{dx}{ds} = 1; \quad \frac{dy}{ds} = 2 \quad (*)$$

2. The initial conditions are

$$x(t) = y(t) = t \quad (\dagger)$$

3. From the characteristic equations,

$$x = s + c(t); \quad y = 2s + d(t)$$

Thus when $s = 0$ (\dagger) implies,

$$x = t = c(t); \quad y = t = d(t)$$

So the solutions to the characteristics are

$$x = s + t; \quad y = 2s + t$$

4. Now we solve

$$\frac{d\varphi}{ds} = \gamma = ye^x = (2s + t)e^{s+t}$$

Note that $\frac{d}{ds}(2se^s) = 2e^s + 2se^s$, so the solution is

$$\varphi(s, t) = (2s - 2 + t)e^{s+t} + c(s)$$

for some constant term $c(s)$. But $\varphi(0, t) = \sin t$, hence

$$\sin t = (t - 2)e^t + c(s) \implies \varphi(s, t) = (2s - 2 + t)e^{s+t} + \sin t + (2 - t)e^t$$

5. Inverting into x, y space, since $s = y - x, t = 2x - y$,

$$\varphi(x, y) = (y - 2)e^x + (y - 2x + 2)e^{2x-y} + \sin(2x - y)$$

§9.5 Classification of second order PDEs

In two dimensions, the general second order PDE is

$$\begin{aligned} \mathcal{L}\varphi \equiv & a(x, y) \frac{\partial^2 \varphi}{\partial x^2} + 2b(x, y) \frac{\partial^2 \varphi}{\partial x \partial y} + c(x, y) \frac{\partial^2 \varphi}{\partial y^2} \\ & + d(x, y) \frac{\partial \varphi}{\partial x} + e(x, y) \frac{\partial \varphi}{\partial y} + f(x, y) \varphi(x, y) \end{aligned} \quad (9.11)$$

The *principal part* is given by

$$\sigma_P(x, y, k_x, k_y) \equiv k^T A k = \begin{pmatrix} k_x & k_y \end{pmatrix} \begin{pmatrix} a(x, y) & b(x, y) \\ b(x, y) & c(x, y) \end{pmatrix} \begin{pmatrix} k_x \\ k_y \end{pmatrix}$$

The PDE is classified by the properties of the eigenvalues of A .

1. If $b^2 - ac < 0$, the equation is *elliptic*. The eigenvalues have the same sign. An example is the Laplace equation, eq. (5.1).
2. If $b^2 - ac > 0$, the equation is *hyperbolic*. The eigenvalues have opposite signs. An example is the wave equation, eq. (3.4).
3. If $b^2 - ac = 0$, the equation is *parabolic*, where at least one eigenvalue is zero. An example is the heat equation, eq. (4.3).

Note that a differential equation may have different classifications at different points (x, y) in space.

§9.6 Characteristic curves of second order PDEs

A curve defined by $f(x, y) = \text{constant}$ is a characteristic if

$$\begin{pmatrix} f_x & f_y \end{pmatrix} \begin{pmatrix} a & b \\ b & c \end{pmatrix} \begin{pmatrix} f_x \\ f_y \end{pmatrix} = 0 \quad (9.12)$$

This is a generalisation of the first order case $u \cdot \nabla f = 0$ where $u = (\alpha, \beta)$. The curve can be written as $y = y(x)$ by the chain rule.

$$\frac{\partial f}{\partial x} + \frac{\partial f}{\partial y} \frac{dy}{dx} = 0 \implies \frac{f_x}{f_y} = -\frac{dy}{dx} \quad (9.13)$$

Substituting into the quadratic form eq. (9.12),

$$a \left(\frac{dy}{dx} \right)^2 - 2b \frac{dy}{dx} + c = 0$$

for which we have a quadratic solution given by

$$\frac{dy}{dx} = \frac{b \pm \sqrt{b^2 - ac}}{a} \quad (9.14)$$

1. Hyperbolic equations have two such solutions, since $b^2 - ac > 0$.
2. Parabolic equations have one solution.
3. Elliptic equations have no real characteristics.

§9.7 Characteristic coordinates

Transforming to characteristic coordinates u, v will set $a = 0$ and $c = 0$ in eq. (9.11). Hence, the PDE will take the **canonical form**

$$\frac{\partial^2 \varphi}{\partial u \partial v} + \dots + = 0 \quad (9.15)$$

where the omitted terms are lower order, e.g. $\varphi_u, \varphi_v, \varphi \dots$

Example 9.4

Consider

$$-y\varphi_{xx} + \varphi_{yy} = 0 \quad (*)$$

Here, $a = -y, b = 0, c = 1$ hence $b^2 - ac = y$. For $y > 0$, the equation is hyperbolic, for $y < 0$ it is elliptic, and for $y = 0$ it is parabolic. Consider the characteristics for

$y > 0$.

$$\frac{dy}{dx} = \frac{b \pm \sqrt{b^2 - ac}}{a} = \pm \frac{1}{\sqrt{y}}$$

Hence,

$$\int \sqrt{y} dy = \pm \int dx \implies \frac{2}{3}y^{\frac{3}{2}} \pm x = C_{\pm}$$

Therefore, the characteristic curves are

$$u = \frac{2}{3}y^{\frac{3}{2}} + x; \quad v = \frac{2}{3}y^{\frac{3}{2}} - x$$

Taking derivatives,

$$u_x = 1; \quad u_y = \sqrt{y}; \quad v_x = -1; \quad v_y = \sqrt{y}$$

Hence,

$$\begin{aligned}\varphi_x &= \varphi_u u_x + \varphi_v v_x = \varphi_u - \varphi_v \\ \varphi_y &= \sqrt{y}(\varphi_u + \varphi_v) \\ \varphi_{xx} &= \varphi_{uu} - 2\varphi_{uv} + \varphi_{vv} \\ \varphi_{yy} &= y(\varphi_{uu} + 2\varphi_{uv} + \varphi_{vv}) + \frac{1}{2\sqrt{y}}(\varphi_u + \varphi_v)\end{aligned}$$

Substituting into the original PDE (*),

$$-y\varphi_{xx} + \varphi_{yy} = y \left(4\varphi_{uv} + \frac{1}{2y^{\frac{3}{2}}}(\varphi_u + \varphi_v) \right)$$

Note, $u + v = \frac{4}{3}y^{\frac{3}{2}}$, hence we have the canonical form

$$4\varphi_{uv} + \frac{1}{6(u+v)}(\varphi_u + \varphi_v) = 0$$

§9.8 General solution to wave equation

The wave equation, eq. (3.4), is

$$\frac{1}{c^2} \frac{\partial^2 \varphi}{\partial t^2} - \frac{\partial^2 \varphi}{\partial x^2} = 0$$

We wish to solve this with initial conditions

$$\varphi(x, 0) = f(x), \quad \varphi_t(x, 0) = g(x) \tag{9.16}$$

Here, $a = \frac{1}{c^2}$, $b = 0$, $c = -1$ hence $b^2 - ac > 0$. The characteristic equation is

$$\frac{dx}{dt} = \frac{0 \pm \sqrt{0 + \frac{1}{c^2}}}{\frac{1}{c^2}} = \pm c$$

Hence the characteristic coordinates are

$$u = x - ct; \quad v = x + ct$$

This yields the canonical form

$$\frac{\partial^2 \varphi}{\partial u \partial v} = 0 \tag{9.17}$$

This may be integrated directly to find

$$\frac{\partial \varphi}{\partial v} = F(v) \implies \varphi = G(u) + \int^v F(y) dy = G(u) + H(v)$$

Imposing the initial conditions at $t = 0$, we find $u = v = x$ and

$$G(x) + H(x) = f(x); \quad -cG'(x) + cH'(x) = g(x)$$

Differentiating the first equation, we find

$$G'(x) + H'(x) = f'(x)$$

We can combine this with the second equation to give

$$H'(x) = \frac{1}{2} \left(f'(x) + \frac{1}{c} g(x) \right) \implies H(x) = \frac{1}{2} (f(x) - f(0)) + \frac{1}{2c} \int_0^x g(y) dy$$

Similarly,

$$G'(x) = \frac{1}{2} \left(f'(x) - \frac{1}{c} g(x) \right) \implies G(x) = \frac{1}{2} (f(x) - f(0)) - \frac{1}{2c} \int_0^x g(y) dy$$

The final solution is therefore

$$\varphi(x, t) = G(x - ct) + H(x + ct) = \frac{1}{2} (f(x - ct) + f(x + ct)) + \frac{1}{2c} \int_{x-ct}^{x+ct} g(y) dy \tag{9.18}$$

Domain of dependence

Waves propagate at a velocity c , hence $\varphi(x, t)$ is fully determined by values of f, g in the interval $[x - ct, x + ct]$. This is the same idea as light cones in special relativity.

§10 Solving partial differential equations with Green's functions

§10.1 Diffusion equation and Fourier transform

Recall the heat equation, eq. (4.3), for a conducting wire given by

$$\frac{\partial \Theta}{\partial t}(x, t) - D \frac{\partial^2 \Theta}{\partial x^2}(x, t) = 0 \quad (10.1)$$

with initial conditions $\Theta(x, 0) = h(x)$ and boundary conditions $\Theta \rightarrow 0$ as $x \rightarrow \pm\infty$. Taking the Fourier transform with respect to x using eq. (8.13),

$$\frac{\partial}{\partial t} \tilde{\Theta}(k, t) = -Dk^2 \tilde{\Theta}(k, t)$$

Integrating, we find

$$\tilde{\Theta}(k, t) = C e^{-Dk^2 t}$$

The initial conditions give $\tilde{\Theta}(k, 0) = \tilde{h}(k)$ and therefore

$$\tilde{\Theta}(k, t) = \tilde{h}(k) e^{-Dk^2 t}$$

We take the inverse Fourier transform to find

$$\Theta(x, t) = \frac{1}{2\pi} \int_{-\infty}^{\infty} \tilde{h}(k) \underbrace{e^{-Dk^2 t} e^{ikx}}_{\text{FT of Gaussian}} dk$$

Hence, by the convolution theorem eq. (8.17),

$$\begin{aligned} \Theta(x, t) &= \frac{1}{\sqrt{4\pi Dt}} \int_{-\infty}^{\infty} h(u) \exp\left(-\frac{(x-u)^2}{4Dt}\right) du \\ &\equiv \int_{-\infty}^{\infty} h(u) S_d(x-u, t) du \end{aligned} \quad (10.2)$$

where the *fundamental solution* is

$$S_d(x, t) = \frac{1}{\sqrt{4\pi Dt}} \exp\left(-\frac{x^2}{4Dt}\right) \quad (10.3)$$

which is the Fourier transform of $\exp(-Dk^2 t)$ (you should know how to derive eq. (10.3) using derivatives or by completing the square). This is also known as the diffusion kernel or the source function.

Note. With localised initial conditions $\Theta(x, 0) = \Theta_0 \delta(x)$, the solution is exactly the fundamental solution:

$$\Theta(x, t) = \Theta_0 S_d(x, t) = \frac{\Theta_0}{\sqrt{4\pi Dt}} \exp(-\eta^2); \quad \eta = \frac{x}{2\sqrt{Dt}} \quad (10.4)$$

where η is the similarity parameter. I.e. for $t \geq 0$ spreads smoothly as a Gaussian.

§10.2 Gaussian pulse for heat equation

Suppose that the initial conditions for the heat equation are given by

$$f(x) = \sqrt{\frac{a}{\pi}} \Theta_0 e^{-ax^2}$$

Then, our eq. (10.2) gives

$$\begin{aligned} \Theta(x, t) &= \frac{\Theta_0 \sqrt{a}}{\sqrt{4\pi^2 Dt}} \int_{-\infty}^{\infty} \exp\left[-au^2 - \frac{(x-u)^2}{4Dt}\right] du \\ &= \frac{\Theta_0 \sqrt{a}}{\sqrt{4\pi^2 Dt}} \int_{-\infty}^{\infty} \exp\left[-\frac{(1+4aDt)u^2 - 2xu + x^2}{4Dt}\right] du \\ &= \frac{\Theta_0 \sqrt{a}}{\sqrt{4\pi^2 Dt}} \int_{-\infty}^{\infty} \exp\left[-\frac{1+4aDt}{4Dt} \left(u - \frac{x}{1+4aDt}\right)^2\right] \exp\left[\frac{-ax^2}{1+4aDt}\right] du \end{aligned}$$

Recall eq. (6.3),

$$\int_{-\infty}^{\infty} \exp\left[-\frac{(u-\mu)^2}{\sigma^2}\right] du = \sigma\sqrt{\pi}$$

The integral above is a Gaussian, so its solution can be read off directly as

$$\Theta(x, t) = \frac{\Theta_0 \sqrt{a}}{\sqrt{\pi(1+4\pi^2 Dt)}} \exp\left[\frac{-ax^2}{1+4aDt}\right] \quad (10.5)$$

So the width of the Gaussian pulse will get wider over time, according to $\sigma^2 \sim t$, as it evolves according to the heat equation. The area is constant, so heat energy is conserved in the system.

§10.3 Forced diffusion equation

Consider the equation

$$\frac{\partial}{\partial t} \Theta(x, t) - D \frac{\partial^2 \Theta}{\partial x^2} = f(x, t) \quad (10.6)$$

subject to homogeneous initial conditions $\Theta(x, 0) = 0$. We construct a two-dimensional Green's function $G(x, t; \xi, \tau)$ such that

$$\frac{\partial}{\partial t} G(x, t) - D \frac{\partial^2 G}{\partial x^2} = \delta(x - \xi) \delta(t - \tau) \quad (10.7)$$

subject to the same homogeneous boundary conditions $G(x, 0; \xi, \tau) = 0$. Consider the Fourier transform with respect to x .

$$\frac{\partial \tilde{G}}{\partial t} + Dk^2 \tilde{G} = e^{-ik\xi} \delta(t - \tau)$$

We can solve this using an integrating factor $e^{Dk^2 t}$ and integrating with respect to time. Since $G = 0$ at $t = 0$,

$$\begin{aligned} \frac{\partial}{\partial t} [e^{Dk^2 t} \tilde{G}] &= e^{-ik\xi + Dk^2 t} \delta(t - \tau) \\ \int_0^t \frac{\partial}{\partial t'} [e^{Dk^2 t'} \tilde{G}] dt' &= \int_0^t e^{-ik\xi + Dk^2 t'} \delta(t' - \tau) dt' \\ e^{Dk^2 t} \tilde{G} &= e^{-ik\xi} \int_0^t e^{Dk^2 t'} \delta(t' - \tau) dt' \\ e^{Dk^2 t} \tilde{G} &= e^{-ik\xi} e^{Dk^2 \tau} H(t - \tau) \end{aligned}$$

where H is the Heaviside step function. Thus,

$$\tilde{G}(k, t; \xi, \tau) = e^{-ik\xi} e^{-Dk^2(t-\tau)} H(t - \tau)$$

The inverse Fourier transform gives the Green's function.

$$G(x, t; \xi, \tau) = \frac{H(t - \tau)}{2\pi} \int_{-\infty}^{\infty} e^{-ik\xi} e^{-Dk^2(t-\tau)} e^{ikx} dk$$

This is a Gaussian; by changing variables into $x' = x - \xi$ and $t' = t - \tau$ we find

$$G(x, t; \xi, \tau) = \frac{H(t')}{2\pi} \int_{-\infty}^{\infty} e^{ikx'} e^{-Dk^2 t'} dk = \frac{H(t')}{\sqrt{4\pi D t'}} \exp\left[-\frac{(x')^2}{4D t'}\right]$$

Converting back,

$$G(x, t; \xi, \tau) = \frac{H(t - \tau)}{\sqrt{4\pi D(t - \tau)}} \exp\left[-\frac{(x - \xi)^2}{4D(t - \tau)}\right] = H(t - \tau) S_d(x - \xi, t - \tau) \quad (10.8)$$

where S_d is the fundamental solution in eq. (10.3).

Thus, the general solution is

$$\Theta(x, t) = \int_0^\infty d\tau \int_{-\infty}^\infty d\xi G(x, t; \xi, \tau) f(\xi, \tau)$$

Let $\xi = u$, then

$$\Theta(x, t) = \int_0^t d\tau \int_{-\infty}^\infty du f(u, \tau) S_d(x - u, t - \tau) \quad (10.9)$$

§10.4 Duhamel's principle

In the above equation, omitting the integral over time, this is exactly the solution as found earlier with initial conditions at $t = \tau$, which was

$$\Theta(x, t) = \int_{-\infty}^{\infty} du f(u) S_d(x - u, t - \tau)$$

The forced PDE with homogeneous boundary conditions can be related to solutions of the homogeneous PDE with inhomogeneous boundary conditions. The forcing term $f(x, t)$ at $t = \tau$ acts as an initial condition for subsequent evolution. Thus, the solution, eq. (10.9), is a superposition of the effects of the initial conditions integrated over $0 < \tau < t$. This relation between the homogeneous and inhomogeneous problems is known as *Duhamel's principle*.

§10.5 Forced wave equation

Consider the forced wave equation, given by

$$\frac{\partial^2 \varphi}{\partial t^2} - c^2 \frac{\partial^2 \varphi}{\partial x^2} = f(x, t) \quad (10.10)$$

with $\varphi(x, 0) = \varphi_t(x, 0) = 0$. We construct the Green's function using

$$\frac{\partial^2 G}{\partial t^2} - c^2 \frac{\partial^2 G}{\partial x^2} = \delta(x - \xi) \delta(t - \tau)$$

with $G(x, 0) = G_t(x, 0) = 0$. We take the Fourier transform with respect to x , and find

$$\frac{\partial^2 \tilde{G}}{\partial t^2} + c^2 k^2 \tilde{G} = e^{-ik\xi} \delta(t - \tau)$$

We can solve this by inspection by comparing with the corresponding initial value problem Green's function eq. (7.26) which has homogeneous solution $\sin kc(t - \tau)$ as $G(x, 0) = 0$, and find

$$\tilde{G} = \begin{cases} 0 & t < \tau \\ e^{-ik\xi} \frac{\sin kc(t - \tau)}{kc} & t > \tau \end{cases}$$

Using the Heaviside function.

$$\tilde{G} = e^{-ik\xi} \frac{\sin kc(t - \tau)}{kc} H(t - \tau)$$

We invert the Fourier transform.

$$G(x, t; \xi, \tau) = \frac{H(t - \tau)}{2\pi c} \int_{-\infty}^{\infty} e^{ik(x - \xi)} \frac{\sin kc(t - \tau)}{k} dk$$

Let $A = x - \xi$, and $B = c(t - \tau)$. By oddness of sine, only the cosine term of the complex exponential remains. Noting the similarity to the Dirichlet discontinuous function,

$$\begin{aligned} G(x, t; \xi, \tau) &= \frac{H(t - \tau)}{\pi c} \int_0^\infty \frac{\cos(kA) \sin(kB)}{k} dk \\ &= \frac{H(t - \tau)}{2\pi c} \int_0^\infty \frac{\sin k(A + B) - \sin k(A - B)}{k} dk \\ &= \frac{H(t - \tau)}{4c} [\operatorname{sgn}(A + B) - \operatorname{sgn}(A - B)] \end{aligned}$$

by eq. (8.16). Since the $H(t - \tau)$ term is nonzero only for $t > \tau$, we must have $B = c(t - \tau) > 0$. The only way that the bracketed term can be nonzero is when $|A| < B$; so $|x - \xi| < c(t - \tau)$. This is the domain of dependence as found before, demonstrating the causality of the relation. Hence,

$$G(x, t; \xi, \tau) = \frac{1}{2c} H(c(t - \tau) - |x - \xi|) \quad (10.11)$$

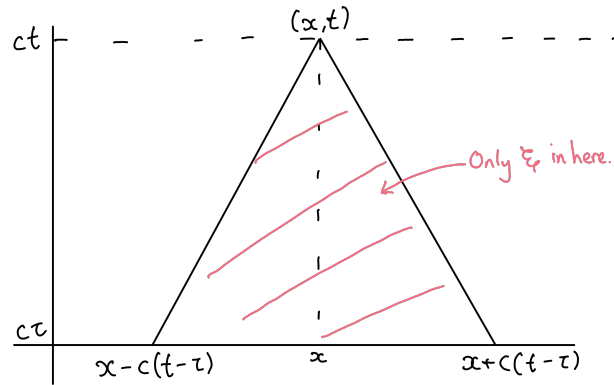

Thus, the solution is

$$\begin{aligned} \varphi(x, t) &= \int_0^\infty d\tau \int_{-\infty}^\infty d\xi f(\xi, \tau) G(x, t; \xi, \tau) \\ &= \frac{1}{2c} \int_0^t d\tau \int_{x-c(t-\tau)}^{x+c(t-\tau)} d\xi f(\xi, \tau) \end{aligned} \quad (10.12)$$

Exercise 10.1. Relate eq. (10.12) to D'Alembert's solution with ICs eq. (9.18) at $t = 0$, $\varphi = 0$, $\varphi_t = g(x)$ as an example of Duhamel's principle.

§10.6 Poisson's equation

Consider

$$\nabla^2 \varphi = -\rho(r) \quad (10.13)$$

defined on a three-dimensional domain D , with Dirichlet boundary conditions $\varphi = 0$ on a boundary ∂D .

§10.6.1 Fundamental solutions

The Dirac δ function, when defined in \mathbb{R}^3 , has the following properties.

1. $\delta(r - r') = 0$ for all $r \neq r'$;
- 2.

$$\begin{cases} \int_D \delta(r - r') d^3r = 1 & r' \in D \\ 0 & \text{otherwise} \end{cases} \quad (10.14)$$

3. $\int_D f(r) \delta(r - r') d^3r = f(r')$.

First, we consider $D = \mathbb{R}^3$ with the homogeneous boundary conditions that $G \rightarrow 0$ as $\|r\| \rightarrow \infty$. This is known as the *free-space* Green's function, denoted G_{FS} ,

$$\nabla^2 G_{\text{FS}}(r, r') = \delta(r - r') \quad (10.15)$$

The potential here is spherically symmetric, so the Green's function is a function only of the distance between the point and the source, i.e. $G(r, r') = G(\|r - r'\|)$. Without loss of generality, let $r' = 0$, so G is a function only of the radius, now denoted r . Integrating the left hand side of Poisson's equation, eq. (10.15), over a ball B with radius r around zero, we find

$$\int_B \nabla^2 G_{\text{FS}} d^3r = \int_{\partial B} \nabla G_{\text{FS}} \cdot \hat{n} dS = \int_{\partial B} \frac{\partial G_{\text{FS}}}{\partial r} r^2 d\Omega$$

where $d\Omega$ is the angle element. This gives

$$\int_B \nabla^2 G_{\text{FS}} d^3r = 4\pi r^2 \frac{\partial G_{\text{FS}}}{\partial r}$$

The right hand side of Poisson's equation gives unity by eq. (10.14), since zero is contained in the ball. Therefore,

$$\frac{\partial G_{\text{FS}}}{\partial r} = \frac{1}{4\pi r^2} \implies G_{\text{FS}} = \frac{-1}{4\pi r} + c$$

Since $G \rightarrow 0$ as $r \rightarrow \infty$, we must have $c = 0$. The fundamental solution is therefore the free-space Green's function given by

$$G(r; r') = \frac{-1}{4\pi \|r - r'\|} \quad (10.16)$$

Thus, Poisson's equation is solved by

$$\Phi(r) = \frac{1}{4\pi} \int_{\mathbb{R}^3} \frac{\rho(r')}{\|r - r'\|} d^3r'$$

§10.7 Green's identities

Consider scalar functions φ, ψ which are twice differentiable on a domain D . By the divergence theorem, *Green's first identity* is

$$\int_D \nabla \cdot (\varphi \nabla \psi) d^3r = \int_D (\varphi \nabla^2 \psi + \nabla \varphi \cdot \nabla \psi) d^3r = \int_{\partial D} \varphi \nabla \psi \cdot \hat{n} dS \quad (10.17)$$

Switching ψ and φ and subtracting from the above, we arrive at *Green's second identity*, where $\frac{\partial \psi}{\partial \hat{n}} = \nabla \psi \cdot \hat{n}$:

$$\int_{\partial D} \left(\varphi \frac{\partial \psi}{\partial \hat{n}} - \psi \frac{\partial \varphi}{\partial \hat{n}} \right) dS = \int_D (\varphi \nabla^2 \psi - \psi \nabla^2 \varphi) d^3r \quad (10.18)$$

Suppose we remove a ball $\mathcal{B}_\varepsilon(r')$ from the domain. Without loss of generality let $r' = 0$. Let φ be a solution to Poisson's equation, so $\nabla^2 \varphi = -\rho$ and let ψ be the free-space Green's function. Thus, the right hand side of the second identity becomes

$$\int_{D \setminus \mathcal{B}_\varepsilon} \left(\varphi \underbrace{\nabla^2 G_{\text{FS}}}_0 - G_{\text{FS}} \nabla^2 \varphi \right) d^3r = \int_{D \setminus \mathcal{B}_\varepsilon} G_{\text{FS}} \rho d^3r$$

The left hand side is

$$\int_{\partial D} \left(\varphi \frac{\partial G_{\text{FS}}}{\partial \hat{n}} - G_{\text{FS}} \frac{\partial \varphi}{\partial \hat{n}} \right) dS + \int_{\partial \mathcal{B}_\varepsilon} \left(\varphi \frac{\partial G_{\text{FS}}}{\partial \hat{n}} - G_{\text{FS}} \frac{\partial \varphi}{\partial \hat{n}} \right) dS$$

For the second integral, we take the limit as $\varepsilon \rightarrow 0$. Let φ be regular, and let $\bar{\varphi}$ be the average value and $\frac{\partial \varphi}{\partial \hat{n}}$ be the average derivative. This integral then becomes

$$\left(\bar{\varphi} \frac{-1}{4\pi\varepsilon^2} - \frac{1}{4\pi\varepsilon} \overline{\frac{\partial \varphi}{\partial \hat{n}}} \right) 4\pi\varepsilon^2 \rightarrow -\varphi(0)$$

For general r' we instead get $-\varphi(r')$.

Combining the above, we find *Green's third identity*, which is

$$\varphi(r') = \int_D G_{\text{FS}}(r; r') (-\rho(r)) d^3r + \int_{\partial D} \left(\varphi(r) \frac{\partial G_{\text{FS}}}{\partial \hat{n}}(r; r') - G_{\text{FS}}(r; r') \frac{\partial \varphi}{\partial \hat{n}}(r) \right) dS \quad (10.19)$$

The second integral provides the ability to use inhomogeneous boundary conditions

§10.8 Dirichlet Green's function

We will solve Poisson's equation $\nabla^2 \varphi = -\rho$ on D with inhomogeneous boundary conditions $\varphi(r) = h(r)$ on ∂D . The Dirichlet Green's function satisfies

1. $\nabla^2 G(r; r') = 0$ for all $r \neq r'$;
2. $G(r; r') = 0$ on ∂D ;
3. $G(r; r') = G_{\text{FS}}(r; r') + H(r; r')$ where H satisfies Laplace's equation, the homogeneous version of Poisson's equation, for all $r \in D$.

Green's second identity, eq. (10.18), with $\nabla^2 \varphi = -\rho$, $\nabla^2 H = 0$ gives

$$\int_{\partial D} \left(\varphi \frac{\partial H}{\partial \hat{n}} - H \frac{\partial \varphi}{\partial \hat{n}} \right) dS = \int_D H \rho d^3r \quad (\dagger)$$

Now, we set $G_{\text{FS}} = G - H$ into Green's third identity, eq. (10.19), to find

$$\varphi(r') = \int_D (G - H)(-\rho) d^3r + \int_{\partial D} \left(\varphi \frac{\partial(G - H)}{\partial \hat{n}} - (G - H) \frac{\partial \varphi}{\partial \hat{n}} \right) dS$$

All of the H terms can be cancelled by substituting in (\dagger) . Now, given $G = 0$, $\varphi = h$ on ∂D , we have

$$\varphi(r') = \int_D G(r; r')(-\rho(r)) d^3r + \int_{\partial D} h(r) \frac{\partial G(r; r')}{\partial \hat{n}} dS \quad (10.20)$$

This is the general solution. The first integral is the Green's function solution, and the second integral yields the inhomogeneous boundary conditions.

Exercise 10.2. Use eq. (10.18) to show that the Green's function is symmetric (3rd identity)

$$G(r, r') = G(r', r), \quad \forall r \neq r'.$$

§10.9 Neumann Green's Function

For Neumann B.Cs, specifying $\frac{\partial \varphi}{\partial \hat{n}} = k(r)$ on ∂D we have

$$\varphi(r') = \int_D G(r; r')(-\rho(r)) d^3r + \int_{\partial D} G(r; r')(-k(r)) dS \quad (10.21)$$

§10.10 Method of images for Laplace's equation

For symmetric domains D , we can construct Green's functions with $G = 0$ on ∂D by cancelling the boundary potential out by using an opposite 'mirror image' Green's function placed outside the domain.

§10.10.1 Laplace's equation on half-space

Consider Laplace's equation $\nabla^2 \varphi = 0$ on half of \mathbb{R}^3 , in particular, the subset of \mathbb{R}^3 such that $z > 0$. Let $\varphi(x, y, 0) = h(x, y)$ and $\varphi \rightarrow 0$ as $\|r\| \rightarrow \infty$. The free space Green's function satisfies $G_{\text{FS}} \rightarrow 0$ as $\|r\| \rightarrow \infty$, but does not satisfy the boundary condition that $G_{\text{FS}} = 0$ at $z = 0$. For G_{FS} at $r' = (x', y', z')$, we will subtract a copy of G_{FS} located at $r'' = (x', y', -z')$. This gives

$$\begin{aligned} G(r, r') &= \frac{-1}{4\pi|r - r'|} - \frac{-1}{4\pi|r - r''|} \\ &= \frac{-1}{4\pi\sqrt{(x - x')^2 + (y - y')^2 + (z - z')^2}} + \frac{1}{4\pi\sqrt{(x - x')^2 + (y - y')^2 + (z + z')^2}} \end{aligned}$$

Hence $G((x, y, 0), r') = 0$, so this function satisfies the Dirichlet boundary conditions on all of the boundary ∂D . We have

$$\begin{aligned} \left. \frac{\partial G}{\partial \hat{n}} \right|_{z=0} &= \left. \frac{\partial G}{\partial z} \right|_{z=0} = \frac{-1}{4\pi} \left(\frac{z - z'}{|r - r'|^3} - \frac{z + z'}{|r - r''|^3} \right) \\ &= \frac{z'}{2\pi} \left((x - x')^2 + (y - y')^2 + (z')^2 \right)^{-3/2} \end{aligned} \quad (10.22)$$

The solution is then given by eq. (10.20) (no sources),

$$\Phi(x', y', z') = \frac{z'}{2\pi} \int_{-\infty}^{\infty} \int_{-\infty}^{\infty} \left[(x - x')^2 + (y - y')^2 + (z')^2 \right]^{-3/2} h(x, y) dx dy \quad (10.23)$$

§10.11 Method of images for wave equation

Consider the one-dimensional wave equation

$$\ddot{\varphi} - c^2 \varphi'' = f(x, t)$$

with Dirichlet boundary conditions $\varphi(0, t) = 0$. We want to solve for $x > 0$.

We create matching Green's functions from eq. (10.11) with opposite sign centred at $-\xi$.

$$G(x, t; \xi, \tau) = \frac{1}{2c} H(c(t - \tau) - |x - \xi|) - \frac{1}{2c} H(c(t - \tau) - |x + \xi|)$$

We can replace the addition of the two terms with a subtraction to instead use Neumann boundary conditions.

Suppose we wish to solve the homogeneous problem with $f = 0$ for initial conditions of a Gaussian pulse. Here, for $x > 0$ we have

$$\varphi(x, t) = \exp\left[-(x - \xi + ct)^2\right] - \exp\left[-(-x - \xi + ct)^2\right] \quad (10.24)$$

The solution travels to the left, cancelling with the image at $t = \frac{\xi}{c}$, which emerges and travels right as the reflected wave.

